



Entrust Datacard™

User's Guide

Entrust Datacard™ CR805™ Retransfer Card Printer

March 2019

Part No. 527691-001, Rev. E

Notice

Please do not attempt to operate or repair this equipment without adequate training. Any use, operation or repair you perform that is not in accordance with the information contained in this documentation is at your own risk.

Trademark Acknowledgments

Datacard is a registered trademark and service mark of Entrust Datacard Corporation in the United States and other countries.

Entrust is a registered trademark and service mark in the United States and other countries.

MasterCard is a registered trademark of MasterCard International Incorporated.

Visa is a registered trademark of Visa International Service Association.

All other product names are the property of their respective owners.

Proprietary Notice

The design and information contained in these materials are protected by US and international copyright laws.

All drawings and information herein are the property of Entrust Datacard Corporation. All unauthorized use and reproduction is prohibited.

Entrust Datacard
1187 Park Place
Shakopee, MN 55379
Phone: 952-933-1223
Fax: 952-933-7971
www.entrustdatacard.com

Copyright © 2016–2019 Entrust Datacard Corporation. All rights reserved.

Compliance Statements

Liability

The WARNING and CAUTION labels have been placed on the equipment for your safety. Please do not attempt to operate or repair this equipment without adequate training. Any use, operation, or repair in contravention of this document is at your own risk.

Safety

The following basic safety tips are given to ensure safe installation, operation, and maintenance of Entrust Datacard™ equipment.

- Connect equipment to a grounded power source. Do not defeat or bypass the ground lead.
- Place the equipment on a stable surface (table) and ensure floors in the work area are dry and non-slip.
- Know the location of equipment branch circuit interrupters or circuit breakers and how to turn them on and off in case of emergency.
- Know the location of fire extinguishers and how to use them. ABC type extinguishers may be used on electrical fires.
- Know local procedures for first aid and emergency assistance at the customer facility.
- Use adequate lighting at the equipment location.
- Maintain the recommended temperature and humidity range in the equipment area.

Regulatory Compliance

EMC Compliance Notice

To ensure compliance of the model RX10 retransfer printer to the radiated emissions requirements for class "A" Information Technology Equipment, be sure to use a shielded Ethernet cable when connecting to your network

Notice for USA (FCC Notice)

This equipment has been tested and found to comply with the limits for Class A computing devices, pursuant to Part 15 of FCC rules. These limits are designed to provide reasonable protection against harmful interference when the equipment is operated in a commercial environment. This equipment generates, uses, and can radiate radio frequency energy. If this equipment is not installed and used in accordance with this instruction manual, it may cause harmful interference to radio communications. Operation of this equipment in a residential area is likely to cause harmful interference in which case the user will be required to correct the interference at their own expense. Changes or modifications not expressly approved by the party responsible for compliance could void the user's authority to operate the equipment.

This device complies with Part 15 of the FCC Rules. Operation is subject to the following two conditions: (1) This device may not cause harmful interference, and (2) this device must accept any interference received, including interference that may cause undesired operation.

Notice for Canada

Industry Canada

This digital apparatus does not exceed the Class A limits for radio noise for digital apparatus set out in the Radio Interference Regulations of the Canadian Department of Communications.

Le présent appareil numérique n'émet pas de bruits radioélectriques dépassant les limites applicables aux appareils numériques de la classe A prescrites dans le Règlement sur le brouillage radioélectrique édicté par le ministère des Communications du Canada.

RSS-Gen, Issue 3, December 2010, Section 7.1.3 User Manual Notice

This Device complies with Industry Canada License-exempt RSS standard(s). Operation is subject to the following two conditions: 1) this device may not cause interference, and 2) this device must accept any interference, including interference that may cause undesired operation of the device.

Cet appareil est conforme avec Industrie Canada RSS standard exemptes de licence(s). Son fonctionnement est soumis aux deux conditions suivantes: 1) ce dispositif ne peut causer des interférences, et 2) cet appareil doit accepter toute interférence, y compris les interférences qui peuvent causer un mauvais fonctionnement du dispositif.

Notice for Europe

The EU Declaration of Conformity can be found on **EntrustDatacard.com** under product compliance.

WARNING: This is a class A product. This equipment is compliant with class A of either CISPR32 or CISPR22. In a domestic/residential environment this equipment may cause radio interference, in which case the user may be required to take adequate measures.

WEEE: The model RX10 retransfer printer uses a lithium coin cell battery. Refer to the service manual for battery removal instructions.

Simplified EU Declaration of Conformity

Entrust Datacard Corporation declares that the following radio equipment: MXD, MX6000, MX6100, PB6500, MX2000, MX2100, SP55k, SP35, SP55, CP40, CP60, CP80, SP75, FP65, SR200, SR300, PX10, PX30, EX30, MPR3800, CR500f, MX1100, RX10, and PB1000 is in compliance with the Directive 2014/53/EU.

The full text of the EU declaration of conformity is available at the following Internet address, <https://www.datacard.com/productcompliance>.

Intentional Radiator Information

Description/Model Number	FCC ID	Frequency	Effective Radiated Power (ERP) mW
PX10 Supplies RFID	GDI-Q20010	13.56MHz	9.16E-06
PX30 Supplies RFID	GDI-Q30030	13.56MHz	9.16E-06
Central Issuance Supplies RFID	GDI-SID004	13.56MHz	1.96E-07
LX30, RX10 Supplies RFID	GDI-506241001	13.56MHz	3.03E-05
EX30 Supplies RFID	GDI-Q30130	13.56MHz	9.16E-06
FP65 Supplies RFID	GDI-Q10055	13.56MHz	3.65E-05
Central Issuance Smartcard Coupler	GDI-50543001	13.56MHz	1.45E-05

EMC Compliance Notice:

For model RX10/Multi-hopper configurations, to ensure compliance with Conducted Immunity standard EN61000-4-6, use USB cables no longer than three meters in length.

Notice for Australia

This is a Class A product. In a domestic environment this product may cause radio interference, in which case the user may be required to take adequate measures.

Notice for China (Simplified Chinese)

警告

此为 A 级产品，在生活环境中，该产品可能会造成无线电干扰。在这种情况下，可能需要用户对干扰采取切实可行的措施。

Notice for Taiwan (Traditional Chinese)

警告使用者：
這是甲類的資訊產品，在居住的環境中使用時，可能會造成射頻干擾，在這種情況下，使用者會被要求採用某些適當的對策。

Notice for Japan

Japanese Voluntary Control Council for Interference (VCCI) class A statement

この装置は、クラス A 情報技術装置です。この装置を家庭環境で使用すると電波妨害を引き起こすことがあります。この場合には使用者が適切な対策を講ずるよう要求されることがあります。 VCCI-A

Korea Communications Commission (KCC) statement

이 기기는 업무용(A급)으로 전자파적합기기로서 판매자 또는 사용자는 이 점을 주의하시기 바라며, 가정외의 지역에서 사용하는 것을 목적으로 합니다.

California Proposition 65 Compliance

WARNING: This product contains chemicals, including lead, known to the State of California to cause cancer, and birth defects or other reproductive harm. ***Wash hands after handling.***



WARNING: This product can expose you to chemicals including Di(2-ethylhexyl)phthalate (DEHP), which is known to the State of California to cause cancer, and Di(2-ethylhexyl)phthalate (DEHP) and Butyl benzyl phthalate (BBP), which are known to the State of California to cause birth defects or other reproductive harm. For more information go to www.P65Warnings.ca.gov and www.datacard.com/CalifPropWarning.

California Lithium Perchlorate Warning

Perchlorate Material - special handling may apply. See www.dtsc.ca.gov/hazardouswaste/perchlorate.

This notice is required by California Code of Regulations, Title 22, Division 4.5, Chapter 33: Best Management Practices for Perchlorate Materials. This product/part includes a battery that contains Perchlorate material.

Battery Precaution



CAUTION: Risk of explosion if battery is replaced by an incorrect type. Dispose of used batteries according to the instructions.

ATTENTION: Risque d'explosion si la batterie est remplacée par un type de batterie incorrect. Jetez les piles usagées selon les instructions.

Revision Log
CR805 Retransfer Card Printer User's Guide

Revision	Date	Description of Changes
01	May 2016	Beta release of this document.
A	November 2016	First release of this document.
B	August 2017	Added new cleaning procedures and laminator support.
C	September 2017	Added multi-hopper support.
D	July 2018	Added modular single hopper support and general updates.
E	March 2019	Updated the printer cleaning instructions.



Contents

Chapter 1: Introduction	1
About This Manual	1
Intended Audience	1
Technical Support	1
Chapter 2: About the Printer	3
About the CR805 Retransfer Card Printer	3
The Front and Right Side of the Printer	4
Single-Hopper Printer	4
Multi-Hopper Printer	5
Multi-Hopper Cartridge	7
The Left Side of the Printer	8
The Back of the Printer	9
Inside the Printer	10
Printer Configuration Label	12
Multi-Hopper Configuration Label	14
Single Hopper Configuration Label	15
Chapter 3: Using the Printer	17
Printer Overview	17
Equipment	17
Tasks and Users	18
Secure Encryption	18
Use the Front Panel	19
Power Button	19
Down Arrow, Up Arrow, and Enter Key	19
User Button and Light	20
Ribbon Light	21
Card Light	21
Use the LCD Panel Menus	22
Retrieve the Printer's Network IP Address	23
Retrieve an IPv4 Address	24
Retrieve an IPv6 Address	25
Print a Test Card	28
Select a Card Stock	29
Select a Color Mode	30
Load and Replace Supplies	31
Load Cards	31
Single-Hopper Printer	31
Use the Exception Slot	32
Multi-Hopper Printer	32
Use the Multi-Hopper Exception Slide	33

Replace the Ink Ribbon	34
Replace the Cleaning Sleeve	36
Replace the Retransfer Film	38
Chapter 4: Print Cards	41
Before You Begin	41
Print Cards from ID Software	42
Print Cards from Other Software	42
Chapter 5: System Maintenance	45
Maintain the Printer	45
Printer Cleaning Schedule	46
Clean the Printer	47
Use the Isopropanol Cleaning Card	48
Single-Hopper Printer	48
Multi-Hopper Printer	49
Run the Isopropanol Cleaning Card	49
Use the Adhesive Cleaning Card	51
Single-Hopper Printer	51
Multi-Hopper Printer	52
Run the Adhesive Cleaning Card	53
Prepare the Printer for Use	54
Clean the Printhead Cam Rollers	56
Clean the Printhead	57
Use a Cleaning Swab	57
Use a Lapping Stick	58
Empty the Printer Reject Tray	59
Chapter 6: Troubleshooting	61
Locate a Problem Within the Card Production System	62
Locate a Problem with Basic Printer Functions	63
Installation Problems	64
USB Installation Troubleshooting	65
Network Installation Troubleshooting	66
Card Printer Driver Problems	66
The Card Printer Driver does not detect the network-connected printer	67
The Card Printer Driver does not detect the USB-connected printer	67
Driver status or Windows print queue does not provide expected data	68
Printer Messages do not display on the PC	69
Card Appearance	69
Tools for Troubleshooting	69
Something did not print	70
Printing includes unexpected data	71
Print quality concerns	72
Magnetic Stripe Troubleshooting	75

Laminator Troubleshooting	77
Advanced Troubleshooting Tools	79
Printer Card Jams	80
Clear a Card Jam in the K1 Horizontal Transport	80
Single-Hopper Printer	80
Multi-Hopper Printer	81
Clear a Card Jam in the K2 Vertical Transport	81
Clear a Card Jam in the Flipper Module	82
Repair a Broken Ink Ribbon or Retransfer Film	83
Messages and Conditions	84
Messages on the Printer LCD	84
Printer Messages	84
Laminator Messages	87
Messages from the Card Printer Driver on the PC	88
Messages from Printer Manager	89
Other Messages	89
Respond to Messages	89
Printer Messages	90
Close and lock doors	90
100: Request not supported	90
103: Printer problem	90
104: Critical problem	90
105: Magstripe data error	91
106: Magstripe data not found	91
107: Magstripe read data error	91
108: Magstripe read no data	92
111: Card not picked	92
112: Card hopper empty	92
113: Close cover to continue	93
114: Cover opened during job	93
116: Magstripe not available	94
117: Reader not available	94
120: User paused the printer	94
122: Magstripe format problem	95
149: Option not installed	95
150: Print while unlocked	95
151: Failed to lock	95
152: Insert new card side 2 up	95
153: Insert same card side 2 up	96
166: C2 supply out or missing	96
167: C2 supply not identified	96
168: C2 supply not supported	96
170: Insert new card side 1 up	96
171: Insert same card side 1 up	97
172: Insert cleaning card	97

173: Improper shutdown	97
175: C2 supply error	97
176: C2 supply type error	98
228: C1 printhead error	98
229: C2 heat sensor error	98
230: C2 heater error.	98
231: C2 heated roller motion error.	98
232: Retransfer debow error	99
233: Smart card contact fail.	99
234: K1 transport card jam	99
235: K2 transport card jam	100
236: Flipper module rotate error	100
237: C1 supply out or missing	100
238: C1 supply not identified	101
239: C1 supply not supported	101
240: C1 supply error	101
241: C1 supply type error	101
242: RT1 reject tray full.	102
243: Card lost	102
245: Configuration error	102
275: Multi-hopper error	102
276: Multi-hopper card jam	102
277: Multi-hopper pick error	103
278: Insert cleaning card in H2.	103
Laminator Messages	103
177: Laminator not available	103
196: Laminator error critical	104
197: Laminator entry card problem.	104
198: L1 area card problem.	104
199: L2 area card problem.	104
200: Laminator exit card problem	105
201: L1 supply problem	105
202: L1 supply out or missing.	105
203: L1 supply type problem	105
204: L1 supply not supported	105
205: L1 supply not identified	106
206: L2 supply problem	106
207: L2 supply out or missing.	106
208: L2 supply type problem	106
209: L2 supply not supported	106
210: L2 supply not identified.	107
211: L1 heater problem.	107
212: L2 heater problem.	107
213: L1 heater sensor problem.	107
214: L2 heater sensor problem.	107

215: L1 heater roller problem	108
216: L2 heater roller problem	108
217: Debow problem	108
218: Impresser problem	108
219: Impresser sensor problem	108
220: Impresser heater problem	109
221: Bar code scanner problem	109
222: Firmware version mismatch	109
223: Laminator system mismatch	109
Driver-Only Messages	110
500: The printer is not available	110
501: The printer connection was lost	110
502: The card data is missing or is not usable	110
504: The card data is missing or is not usable	110
505: USB communication issue	111
506: A card is currently processing	111
507: The printer is unlocked	111
508: The printer is shutting down	111
509: The printer is offline or suspended	111
510: The printer is unlocked	111
Driver SDK Messages	112
511: Cannot lock or unlock the printer. Locks are not installed.	112
512: Cannot lock or unlock the printer. The password is incorrect or invalid.	112
513: Cannot lock or unlock the printer. The printer is busy.	112
514: Cannot lock or unlock the printer. The cover is open.	112
515: Failed to lock or unlock the printer. The locks did not function.	112
516: Timeout expired before bar code could be read.	112
517: Wrong printer job ID.	112

Appendix A: CR805 Card Printer with Inline Lamination	A-1
About the Laminator System	A-1
Outside the Laminator	A-2
Laminator Back and Left Side	A-2
Laminator Status Light	A-3
Laminator Front and Right Side	A-3
Inside the Laminator	A-4
Laminator Configuration Label	A-5
Laminator Setup	A-6
Laminator Overlay Materials	A-6
Load Laminator Overlay Material	A-8
Card Design	A-10
Verify Setup	A-10
Empty the Laminator Reject Tray.	A-11
Clear a Laminator Card Jam.	A-11
Clean the Laminator.	A-12

Chapter 1: Introduction



About This Manual

This manual provides user information for the Entrust Datacard™ CR805™ Retransfer Card Printer. The manual includes:

- An overview of printer components and options, and a description of the system label.
- How to use the printer, including how to power the printer on and off, how to use the front panel and LCD menus, how to print a test card, how to load and replace supplies, and the basics of card processing.
- How to perform routine maintenance and troubleshooting tasks.

An additional *Installation and Administrator's Guide* is available for use by administrators or other professionals responsible for setting up the printer. Refer to the *Owner's Library* CD.

Intended Audience

The manual is intended for the printer operator who is responsible for printing cards, loading and replacing supplies, maintaining the printer, and troubleshooting error conditions.

Technical Support

Use the following to contact Entrust Datacard Technical Support.

US Phone Number	1-800-328-3996
North America	Email: north.america.cust.serv@entrustdatacard.com
Latin America and Caribbean	Email: americas@entrustdatacard.com
Europe, Middle East, and Africa	Email: emea.customer.service@entrustdatacard.com
Asia Pacific	Email: dcap.admin@entrustdatacard.com



Chapter 2: About the Printer

2

This chapter describes how to identify and access the components of the CR805 Retransfer Card Printer.

About the CR805 Retransfer Card Printer

The CR805 Retransfer Card Printer uses retransfer technology to produce high-quality, over-the-edge printing on a variety of PVC and non-PVC card materials. The retransfer process provides a reliable print quality on card surfaces that have minor variations, such as those due to smart chips or RFID antennas embedded in the card.

The retransfer printing process uses two types of supply: a color pigment ink ribbon and a retransfer film. Heat from a thermal printhead causes the ink pigment to release from the ribbon and adhere to the retransfer material. The film is then bonded to the card using a heat and pressure process that also applies the film to the edges of the card. The printer also has the ability to apply two layers of the retransfer film on the front side or on both sides of a card, for added durability.

The printer supports several types of color ink ribbon. The ribbon typically contains the following panels: cyan, magenta, yellow, black, and primer (CMYKP). Ink ribbons also may include an inhibitor panel that prevents any ink or retransfer material from being applied to areas of the card that have a magnetic stripe or signature panel, or an ultraviolet fluorescent (F) panel. Refer to the printer's *Installation and Administrator's Guide* for a list of ink ribbons available for the printer.

The printer prints at a resolution of 600 x 600 dpi. It can print on one side or both sides of the card. It also can encode data on a magnetic stripe or a smart card chip. Magnetic stripe and contact or contactless smart card capabilities are optional.

A 125-card input and 25-card output hopper are standard on non-locking CR805 card printers. CR805 card printers with locks are manufactured without an input hopper, which allows you to install either a 125-card single hopper, or a multi-hopper with six input hoppers, each with a 125-card capacity. An optional 125-card output hopper also is available and can be installed without tools on single-hopper printers. In addition, an optional upgrade kit allows you to install a Wi-Fi Dongle in the printer.

An optional laminator also is available when you purchase your printer, or as a field upgrade (refer to [Appendix A: "CR805 Card Printer with Inline Lamination"](#)).

Refer to ["Printer Configuration Label"](#) on [page 12](#) for more information about identifying the factory-installed options in the printer.

The Front and Right Side of the Printer

Use the following sections to become familiar with the printer.

Single-Hopper Printer

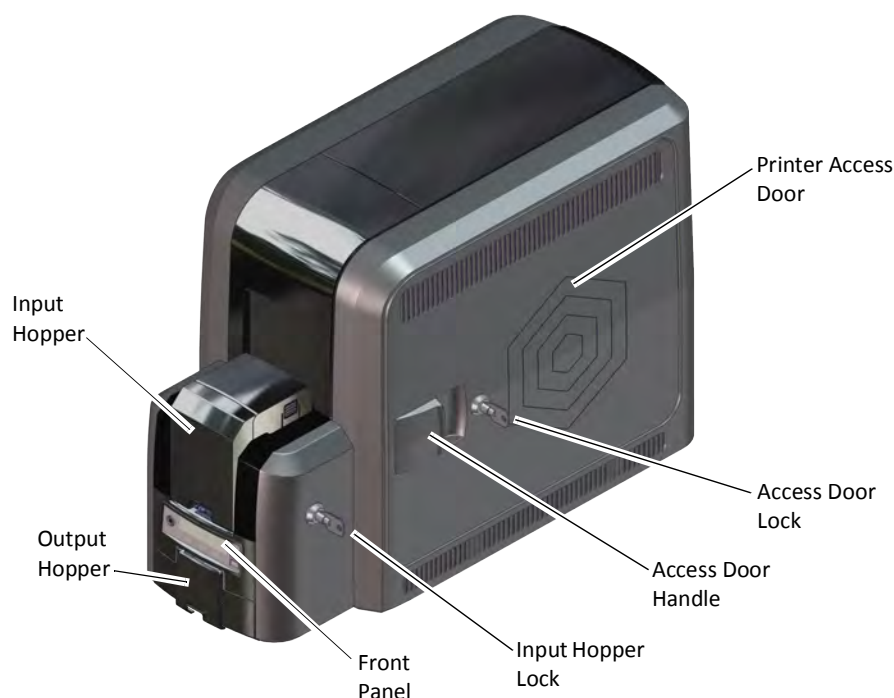

Input Hopper

The input hopper holds cards for printing. The hopper holds up to 125 cards (0.030 in. or 0.762 mm thickness).

Note: the input hopper can be removed from the printer for secure storage.

Output Hopper

The output hopper holds up to 25 completed cards.

Front Panel

The front panel allows you to work with the printer. It includes the POWER button, the USER button, status lights, and the LCD panel with navigation keys. Refer to [“Use the Front Panel”](#) on [page 19](#) for a description of the front panel items.

Input Hopper Lock

The input hopper lock secures the input hopper. The lock can be opened using a key, or by using the Card Printer Driver SDK with your application. Refer to the *Windows XPS Driver Software Development Kit Programmer’s Reference Guide* for more information.

Sending a command to open the lock opens all locks on the printer and on any attached component.

Printer Access Door

The access door provides access to the printer supplies and to the rear access door release. Open the door to replace supplies or clear a card jam. A slot inside the door holds the printer *User Reference Guide*, which contains instructions for performing routine printer tasks.

Access Door Handle

The handle allows you to open the printer access door.

Access Door Lock

Some printers also may have a lock on the access door. Unlock the door to access the inside of the printer. The lock can be opened using the key or through a command issued by an application.

Sending a command to open the lock opens all locks on the printer and on any attached component.

Multi-Hopper Printer

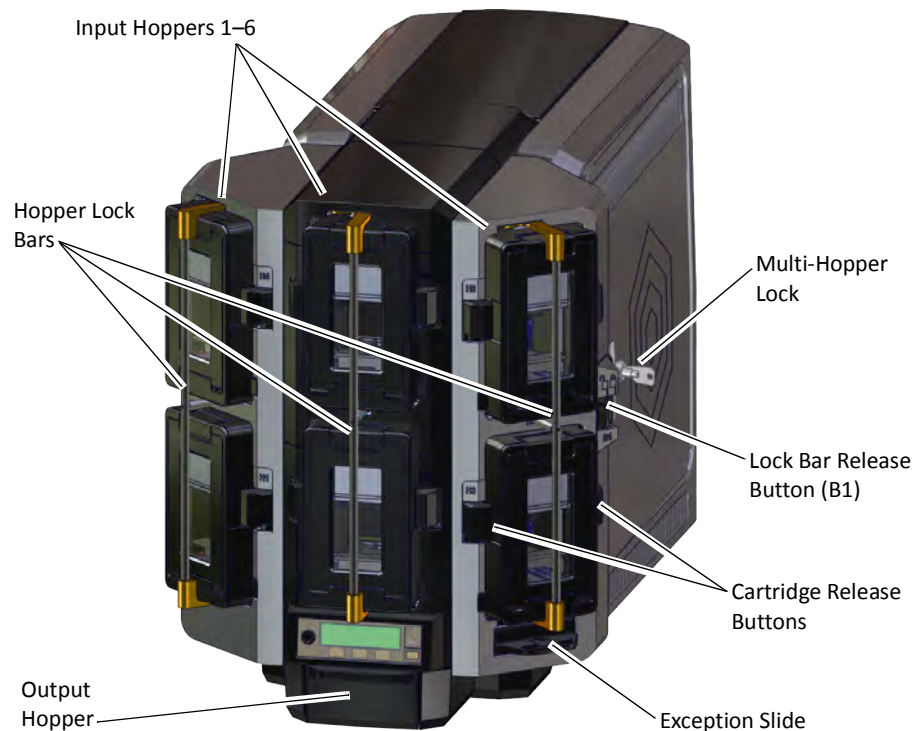

Input Hoppers 1 – 6

Each hopper cartridge in the multi-hopper holds up to 125 cards (0.030 in. or 0.762 mm thickness).

Output Hopper

The output hopper holds up to 25 completed cards.

Multi-Hopper Lock	<p>The multi-hopper lock secures all six input hoppers. The lock can be opened using a key, or by using the Card Printer Driver SDK with your application. Refer to the <i>Windows XPS Driver Software Development Kit Programmer's Reference Guide</i> for more information.</p> <p>Sending a command to open the lock opens all locks on the printer and on any attached component.</p>
Lock Bar Release Button (B1)	<p>The release button (B1) releases the lock bars in front of the input hopper cartridges. Slide the button to the left to release the bars. You must have unlocked the multi-hopper using the key or a software command before the lock bars can be released.</p>
Hopper Lock Bars	<p>The lock bars rotate to the left to allow access to the hopper cartridge doors, so that you can load cards into the cartridges.</p>
Cartridge Release Buttons	<p>The cartridge release buttons allow you to remove the cartridge from the multi-hopper unit. Push in the buttons, squeeze the cartridge, and pull it out from the multi-hopper.</p> <p>Notes:</p> <ul style="list-style-type: none"> • You do not need to remove a hopper cartridge to load cards. • Hopper cartridges can be removed for secure storage.
Exception Slide	<p>The exception slide allows you to insert a single card into the printer without unlocking the multi-hopper or opening a hopper cartridge. Refer to “Use the Multi-Hopper Exception Slide” on page 33.</p>

Multi-Hopper Cartridge

The multi-hopper cartridges can be pulled out from the multi-hopper unit. You can remove the cartridges with the cards inside and store them securely, if necessary.

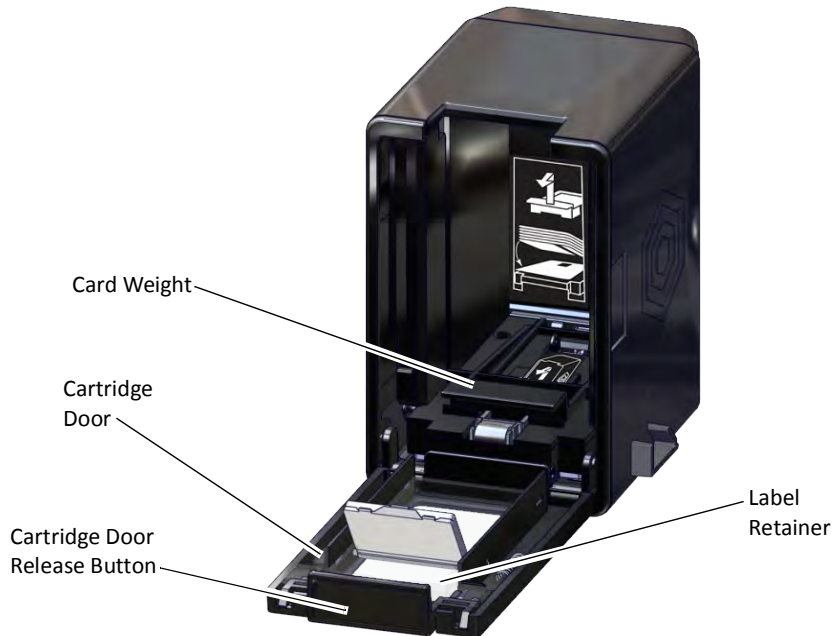

Cartridge Door Release Button

The door release button allows you to open the cartridge door. Press down on the release button.

Cartridge Door

The cartridge door swings down to provide access to the cartridge to load cards.

Card Weight

The card weight maintains a downward pressure on the loaded cards so that they enter the printer properly. Lift the card weight to the top of the cartridge and gently pull it forward until it locks in position. A diagram inside the cartridge shows how to position the card weight and load cards.

Note: Do not place the cards on top of the card weight.

Label Retainer

The label retainer allows you to insert a paper label inside the cartridge door. Use a label to identify the cartridge number or the type of cards loaded in each cartridge. Use a flathead screwdriver to open the label retainer door.

The Left Side of the Printer

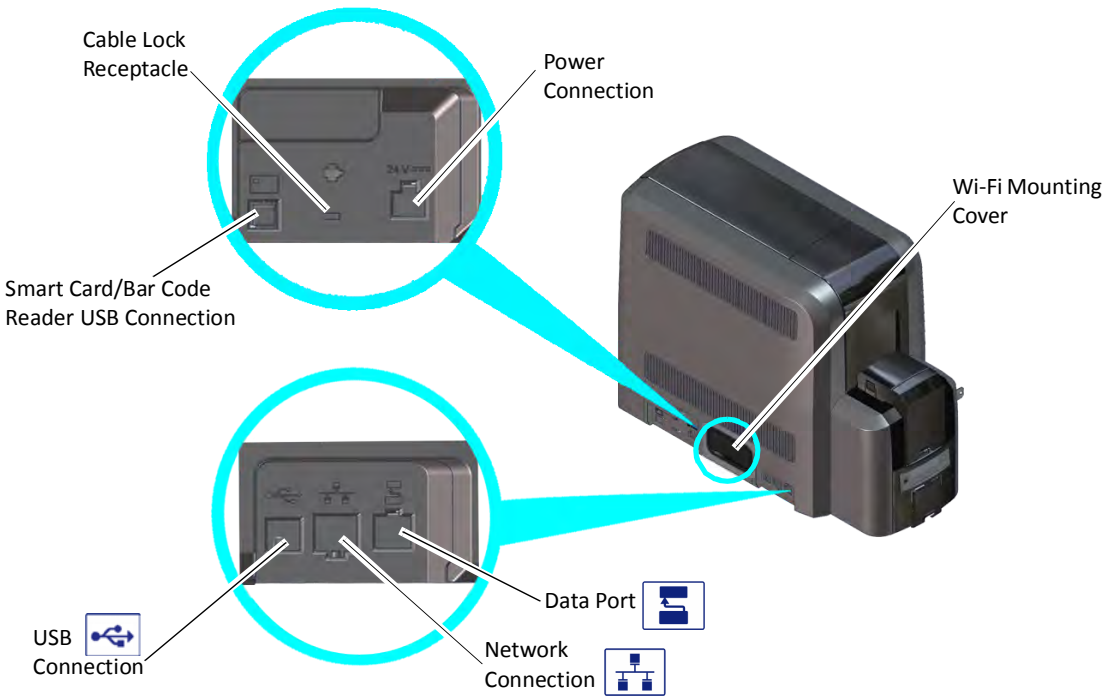

- Power Connection** The power connection provides a plug-in connector for the printer power supply.
- Cable Lock Receptacle** The receptacle allows you to insert the security plate before attaching the optional cable lock.
- Smart Card/Bar Code Reader USB Connection** The connection allows you to connect a loosely coupled smart card reader and bar code reader (used by some printers) to the computer.
- Data Port** The data port allows you to connect the printer to another component, such as a laminator.
- Network Connection** The network connection allows you to connect the printer to an Ethernet network.
- USB Connection** The USB connection allows you to connect the printer directly to a computer.
- Wi-Fi Mounting Cover** The mounting cover in Wi-Fi ready system enclosures allows you to install the optional Wi-Fi Dongle in the printer. Refer to the *Wi-Fi Upgrade Installation Instructions* for complete information.

The Back of the Printer



Rear Access Door

The rear access door allows you to clear a card jam in the vertical transport. You must open the printer access door to reach the rear access door release (K3). Refer to [“Inside the Printer”](#) on [page 10](#) for information about how to open the rear access door.

Rear Door Fan

The fan provides ventilation in the printer to cool the card after the retransfer process.

Inside the Printer

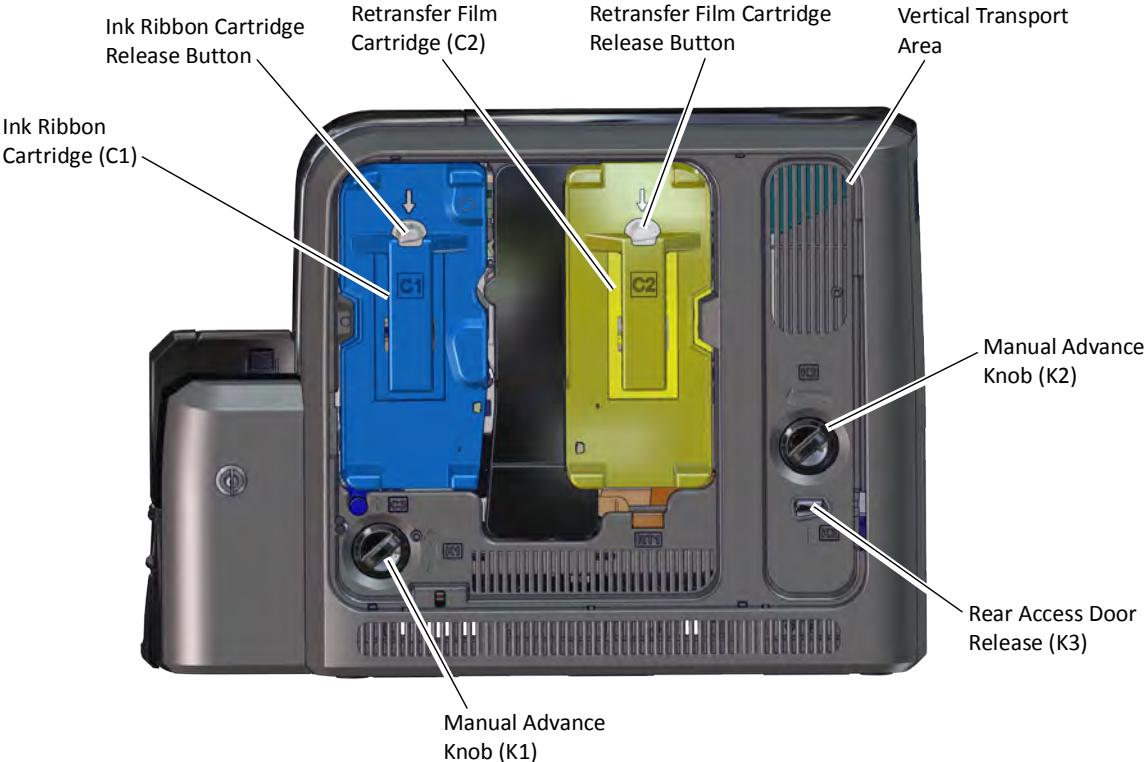

- Ink Ribbon Cartridge (C1) (blue)** The ink ribbon cartridge (C1) holds the ink print ribbon.
- Retransfer Film Cartridge (C2) (yellow)** The retransfer film cartridge (C2) holds the retransfer film.
- Cartridge Release Buttons** The ink ribbon and retransfer film cartridge release buttons allow you to remove the cartridges from the printer for loading or error recovery. Press the release button and pull the cartridge out from the printer.
- Vertical Transport** The vertical transport area houses the magnetic stripe unit and the smart card reader. Some CR805 printers also may include an optional bar code reader that reads and verifies the bar code on specialized pre-serialized cards.

Rear Access Door Release (K3) The rear access door release (K3) opens the rear access door in the back of the printer to clear a card jam in the vertical transport.

Manual Advance Knob (K1) The manual advance knobs allow you to move a card inside the printer (K1) or in the vertical transport area (K2) to clear a card jam. The K2 knob is present only if a magnetic stripe unit or smart card reader is installed in the printer.

Manual Advance Knob (K2)

The following illustration shows the inside of the printer when the ink ribbon and retransfer cartridges are removed.

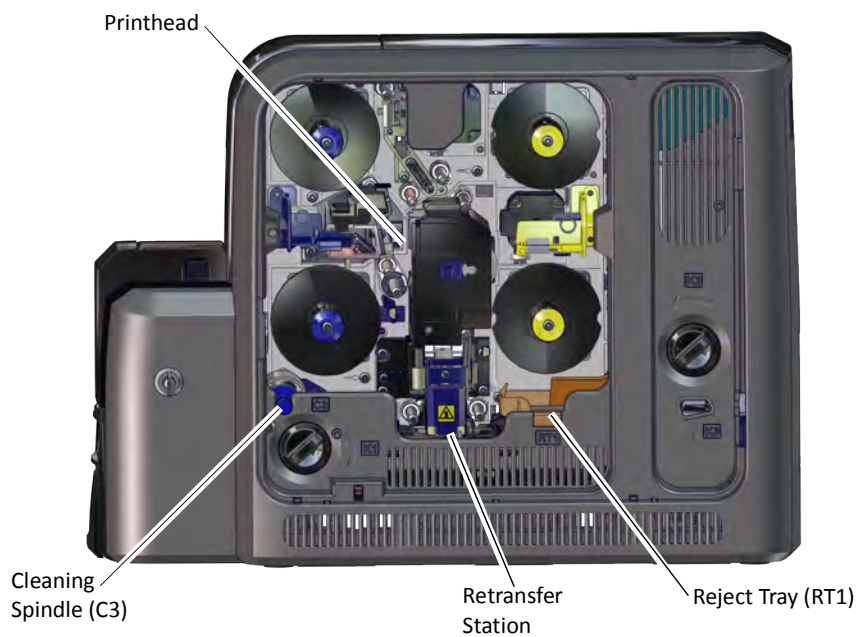

Printhead The printhead prints the card data on the retransfer film using the ink ribbon.

Cleaning Spindle (C3) The cleaning spindle (C3) holds the replaceable cleaning sleeve, which removes dust and other particles from cards to maintain print quality.

Retransfer Station

The retransfer station houses the heated roller that bonds the retransfer film containing the printed image to the surface of the card.

Reject Tray (RT1)

The reject tray (RT1) holds unfinished cards or cards that were not processed properly. Empty the reject tray regularly. Refer to [“Empty the Printer Reject Tray”](#) on [page 59](#).

Note: If your system includes a laminator, the printer reject tray is not used. Cards are placed in the laminator reject tray. Refer to [“Laminator Back and Left Side”](#) on [page A-2](#).

Printer Configuration Label

The printer system configuration label shows the components installed when the printer was built. It provides information that is useful when requesting service. The label is located on the inside of the printer access door, and on the printer frame behind the retransfer film cartridge (you must remove the cartridge to see the label).

The label shows the following information:

- Printer model and serial number
- Configuration, which includes the factory-installed options in the printer
- Date and country of assembly
- MAC address to use when the printer is connected via an Ethernet network

Additional labels may be attached to the printer to indicate components installed by the dealer or sales group after the printer was manufactured.

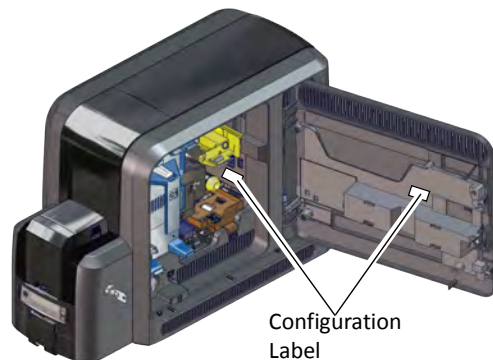



Option	Configuration Code
Input Hopper	H0=No Hopper (Modular Single Hopper or Multi-Hopper Ready) H1=125 Card Input Hopper
Duplex	D0=Simplex D1=Duplex
Magnetic Stripe	M1=ISO M2=JIS blank=No Magnetic Stripe option
Smart Card	Sx=Smart Card option, where x indicates the type of smart card reader installed in the printer (refer to the printer's <i>Installation and Administrator's Guide</i> for a list of smart card readers supported by the printer and their option codes) blank=No Smart Card option
Bar Code Scanner	B2=Bar Code Scanner blank=No Bar Code Scanner
Locks	L1=H1 Lock blank=No locks
Wi-Fi	W1=Wi-Fi Dongle blank=No Wi-Fi

Multi-Hopper Configuration Label

The multi-hopper configuration label is located on the back of the multi-hopper. After the multi-hopper is attached to the printer, a second label should be added on the inside of the printer access door, next to the printer configuration label.

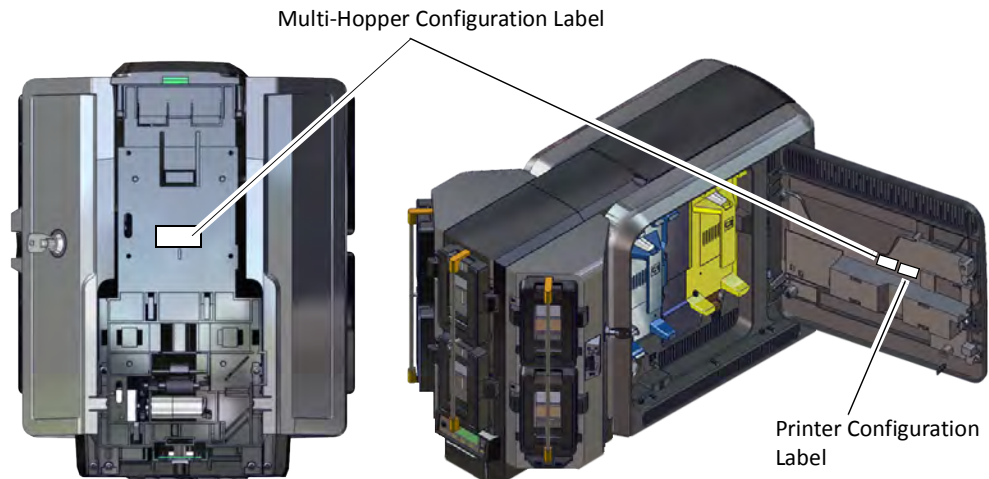

The label shows the following information:

- The name of the multi-hopper module
- Serial number
- Part number
- Configuration code
- Date and country of assembly

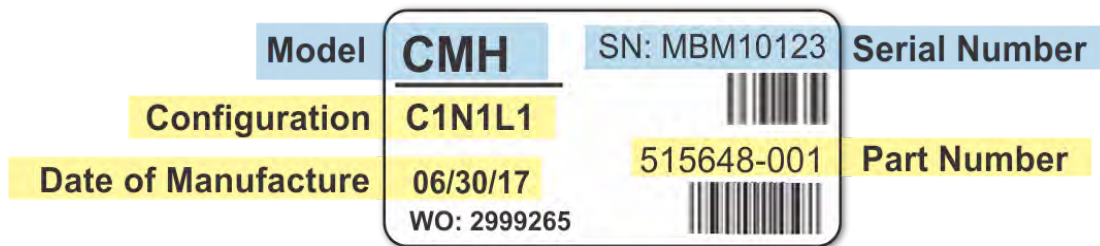

Option	Configuration Code
Hopper Cassette Type	C1=6 125-Card Removable Input Hoppers
Printer Type	N1=CR805, CR825, or CE875
Locks	L1=Multi-Hopper Lock blank=No lock

Single Hopper Configuration Label

The single hopper configuration label is located on the back of the modular single hopper. After the hopper is attached to the printer, a second label should be added on the inside of the printer access door, next to the printer configuration label.

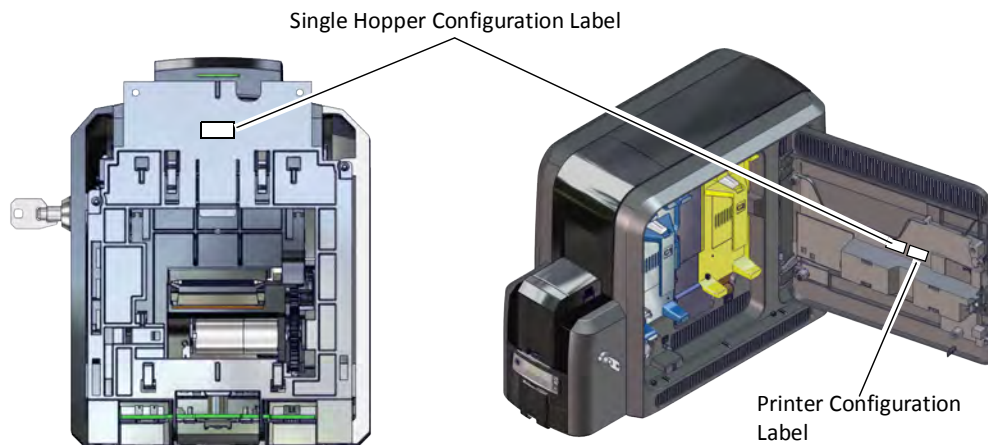

The label shows the following information:

- Serial number
- Part number
- Configuration code
- Date and country of assembly

Module ID Number	MID#: MDM00001	06/30/18	Date of Manufacture
		523251-001	Part Number
		CONFIG	Configuration
		C1N1L1	

Option	Configuration Code
Hopper Cassette Type	C1=125-Card Removable Input Hopper
Printer Type	N1=CR805, CR825, or CE875
Locks	L1=Hopper Lock blank=No lock



Chapter 3: Using the Printer

3

This chapter describes how to perform the basic tasks required to operate the printer.

Printer Overview

The CR805 Retransfer Card Printer is used with other equipment and software to create a card personalization system. The system produces cards for a specific purpose, and the cards must meet defined requirements.

Equipment

The system can include:

- A PC, with software to support the printer, such as:
 - The XPS Card Printer Driver for Windows.
 - ID software designed specifically to capture, format, and save the data for cards, such as Datacard® TruCredential™ Suite Software.
 - A retail application, such as Microsoft Word.
- Capture devices (optional), such as:
 - A digital camera connected to the PC to take photos.
 - A signature capture pad, fingerprint reader, or PIN pad.
- The printer with supplies and a facility power source.
- A data connection between the printer and PC, which can be a USB connection or a network connection. (You cannot use both with one printer.)

Tasks and Users

Typical roles in a card personalization system include:

- The operator, who makes cards, loads supplies, and handles minor problems such as card jams.
- The system administrator, who sets up the card printer and other hardware, sets up card designs, configures card production software, and identifies the best use of the card printer in the organization

Secure Encryption

Secure encryption means that all data entered is converted into a secure form of code by your software application before it is sent to the system. The printer decrypts the code and sends the data to the magnetic stripe or smart card chip on the card.

The printer uses TLS 1.2 encryption for maximum security. Refer to the printer's *Installation and Administrator's Guide* for complete information about using secure printing.

Use the Front Panel

The front panel of the printer provides the controls you need to operate the system. The front panel controls are described in detail in the following sections.

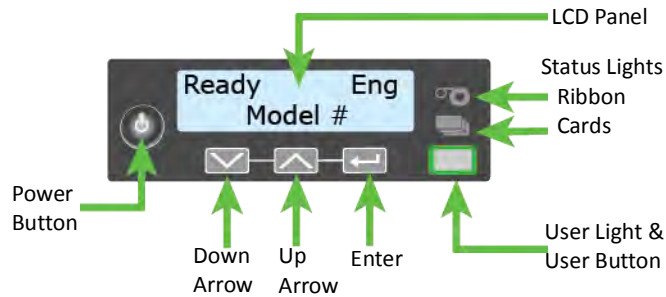

Power Button

Press the POWER button for 1 to 2 seconds to power on the printer. All lights show steady amber while the printer powers on.

To power off the printer, press the POWER button for 1 to 2 seconds until the printer begins to shut down.

To power off the system while processing cards, press the button for 2 or more seconds. Card jobs in the printer do not complete and are sent to the reject tray.



We recommend that you do not unplug the printer power cord to power off the printer.

Down Arrow, Up Arrow, and Enter Key

Use the arrow keys to move through the printer menu system, and the ENTER key to make a selection.

Press the up or down arrow key while the LCD panel displays **Ready** to display additional information about the printer on line 2, including the firmware version, printer model, serial number, IP address, and supply part numbers. If the system includes a laminator, the laminator firmware version and laminator serial number also display. If you do not press a key for 30 seconds, the LCD panel returns to the default **Ready** message.









When you use the arrow keys to view the printer IP address, only the IPv4 address displays. To see the IPv6 addresses available to the printer, you must use the LCD Status menu. Refer to [“Retrieve an IPv6 Address”](#) on page 25.

User Button and Light



The printer's USER button displays with a border of light that indicates the system status. Use the USER button to:

- Suspend the printer—press the USER button when the LCD panel displays **Ready**.
- Clear a message (recover from an error)—press the USER button once.
- Cancel all jobs and clear all pending error messages—press the USER button for two seconds or more.
- Determine whether the system is ready, busy, or not available. Indicators include the following. Refer to [“Messages and Conditions”](#) on [page 84](#) for a list of the LCD messages that correspond to the USER light.

Light	Description	
Off	The printer is off or suspended.	
Green	The printer is ready.	
Blinking green	The printer is busy. OR An attached component has an error.	
Amber	The printer is not ready. OR The POWER button was pressed to turn off the printer.	
Blinking amber	The printer has an error.	
Color Cycle: Amber, Green, Light Green, Off	The printer is not ready or a secure door on the printer is unlocked. The colors cycle quickly. Close and Lock Doors displays on the LCD panel if no other message is present.	



Ribbon Light

The ribbon light indicates the status of a supply in the printer or in an attached component. Indicators include the following. Refer to “[Messages and Conditions](#)” on [page 84](#) for a list of the LCD messages that correspond to the ribbon light.

Light	Description	
Off	The supply levels are okay.	
Blinking amber	A blinking light indicates one of the following: <ul style="list-style-type: none">• A problem with a printer supply.• The printer supply level is low. The light blinks slowly (every 2 seconds).• The printer supply is out. The light blinks quickly (every 1/2 second).	
Blinking green	There is a problem with a supply in an attached component.	

Card Light

The card light indicates the status of cards in the printer or an attached component. Indicators include the following. Refer to “[Messages and Conditions](#)” on [page 84](#) for a list of the LCD messages that correspond to the card light.

Light	Description	
Off	The cards are okay.	
Blinking amber	A blinking light indicates either of the following: <ul style="list-style-type: none">• No card is detected for the print job. Insert a card to continue printing.• A scheduled printer cleaning is due. Insert a cleaning card now, or set aside time to run a cleaning card. Refer to “Clean the Printer” on page 47.	
Blinking green	There is a card problem in an attached component.	

Use the LCD Panel Menus

The LCD panel shows the printer’s menu system and displays messages and conditions.

For a list of error messages and recovery information, refer to “Respond to Messages” on page 89.

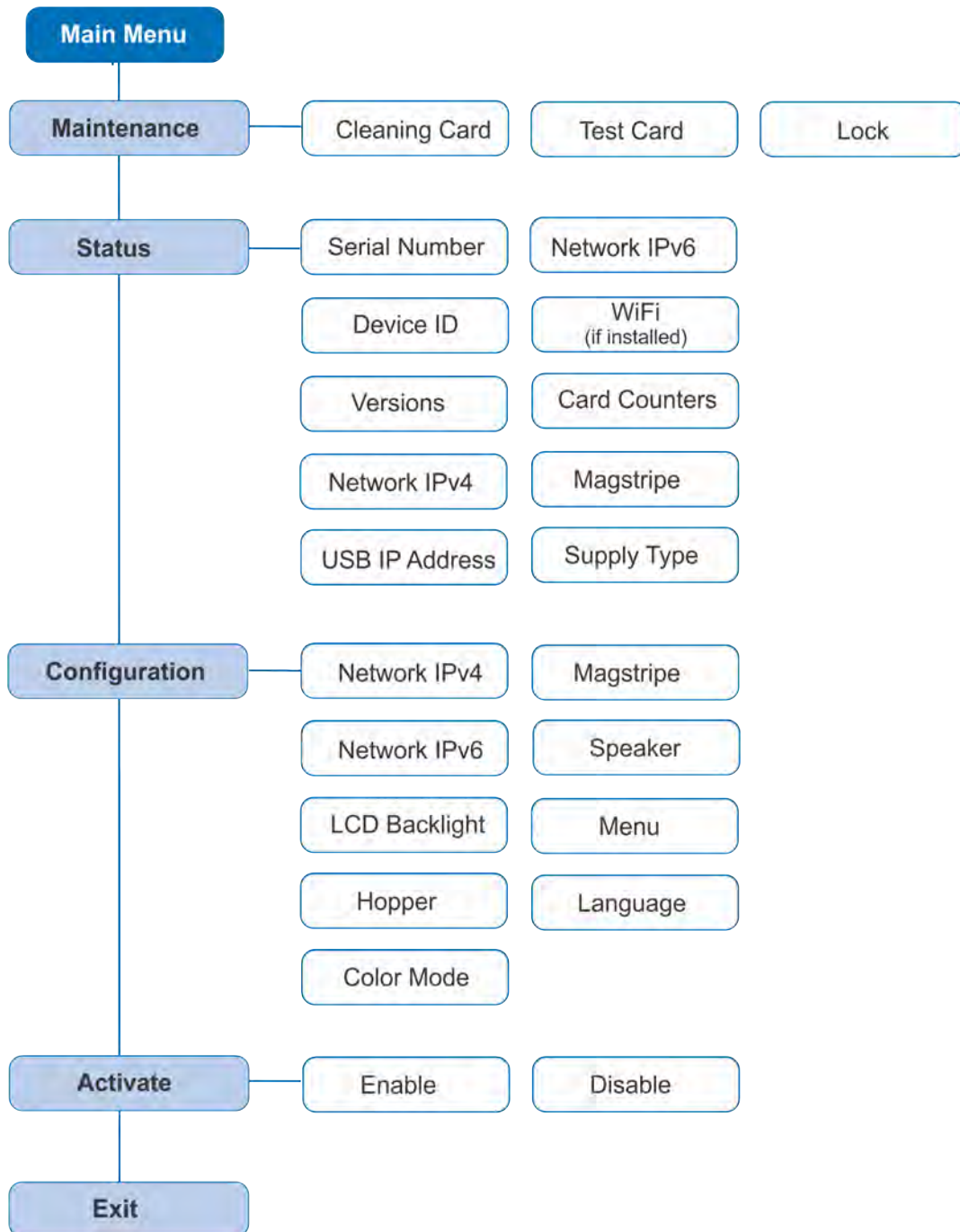

When the printer is in the **Ready** status, the LCD displays the model number of the printer.



Press the **USER** button to suspend the printer. Then, press **ENTER** to enter the menu system. Use the arrow keys to move through the menus, and press **ENTER** to make a selection. The menu system has four major branches:

- Use the **Maintenance** menu to run a cleaning card, print a test card, or reset the locks on a system with locks.
- Use the **Status** menu to see settings and data about the printer.
- Use the **Configuration** menu to change settings.
- Use the **Activate** menu to enable or disable the printer.



The Activate menu is used only during installation or removal of financial systems that require activation.

HINTS & TIPS

- You can access the menu system when **Ready** displays on line 1 of the LCD panel.
- The printer returns to the **Ready** status after 2 minutes of no activity. Changes that have not been applied are lost.
- To leave a selection without changing the value, press the up or down arrow key until **Exit** displays, and then press **ENTER**.

Retrieve the Printer's Network IP Address

You must know the printer IP address to perform some tasks. For example, the XPS Card Printer Driver asks you to enter the network IP address during installation. You also use the IP address when launching Printer Manager, the printer's web interface, from a browser window.

To display the IP address, you can do one of the following:

- Press the up or down arrow key while the printer displays **Ready**. Refer to [“Down Arrow, Up Arrow, and Enter Key”](#) on [page 19](#).
- Use the LCD menu system Status menu.



If the printer is configured to use a static IP address, the printer's front panel displays the address even when the printer is not connected to a network. In addition, the LCD displays a “+” if the network is active, or a “-” if the network is inactive, as a prefix to the static IP address.

The printer supports both IPv4 and IPv6 addressing. Because an IPv6 address is much longer than an IPv4 address, the LCD displays the two types of addresses differently.

Retrieve an IPv4 Address

Do the following to display an IPv4 address using the Status menu. You also can display the subnet mask, gateway address, and MAC address, if necessary.

Begin with the printer power connected, and the printer connected to the network.

1. Press the POWER button to power on the printer, if necessary.
2. Access the **Status** menu in the LCD menu:
 - a. Press the USER button to suspend the printer.

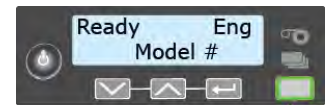

- b. Press ENTER to enter the menu system.

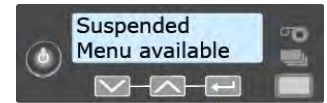

- c. Press the down arrow to display **Status** on line 2.



- d. Press ENTER to enter the **Status** menu.

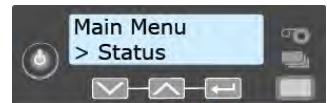

- e. Press the down arrow until **Network IPv4** displays on line 2.

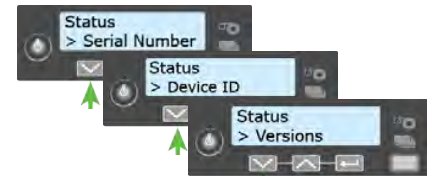

- f. Press ENTER to display the **Network IPv4** menu.

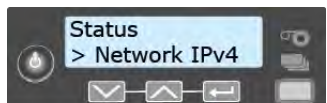

3. Press the down arrow until **IP Address** displays on line 2.

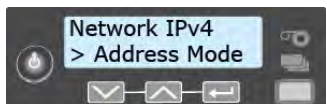

4. Press ENTER to display the IP address. Record the IP address.

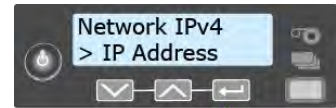

5. Press ENTER to return to the Network IPv4 menu. **Subnet Mask** displays on line 2.

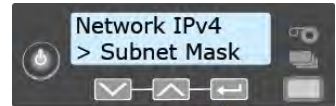

6. Press ENTER to display the subnet mask. Record it, if necessary.



7. Press ENTER to return to the Network IPv4 menu. **Gateway Address** displays on line 2.

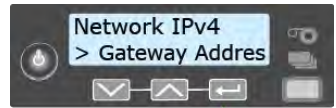

8. Press ENTER to display the gateway address. Record it, if necessary.



9. Press ENTER to return to the Network IPv4 menu.

10. Press the down arrow to scroll to **Exit** on line 2.

11. Press ENTER. Then, press the USER button to return the printer to **Ready**. The USER button glows green.

Retrieve an IPv6 Address

A printer on an IPv6 network can be configured to use one or more of the following methods, depending on how the network is set up:

- **Link Local IPv6 address:** The printer and PC clients are restricted to the same subnet. Link local is enabled automatically when IPv6 is enabled and offers the best security for your network.
- **DHCPv6:** A DHCPv6 server is externally configured to give out an IPv6 address.
- **Stateless Address AutoConfiguration (SLAAC):** One or more routers with IPv6 enabled on the subnet give out a subnet prefix that allows access to IP addresses.
- **Manual IPv6 Address:** The printer has a designated IPv6 address on a specified subnet. The address does not change without manual intervention. This is similar to an IPv4 static IP address.

The method used is enabled or disabled using the LCD Configuration menu. Refer to the printer's *Installation and Administrator's Guide* for more information about enabling IPv6.

To display an IPv6 address using the Status menu, do the following.

Begin with the printer power connected, and the printer connected to the network.

1. Press the POWER button (if needed) to power on the printer.
2. Access the **Status** menu in the LCD menu:
 - a. Press the USER button to suspend the printer.

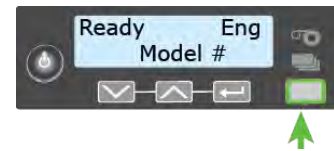

- b. Press ENTER to enter the menu system.

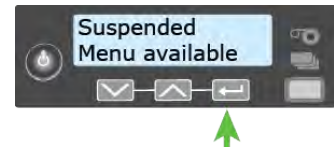

- c. Press the down arrow to display **Status** on line 2.



- d. Press ENTER to enter the **Status** menu.



- e. Press the down arrow until **Network IPv6** displays on line 2.

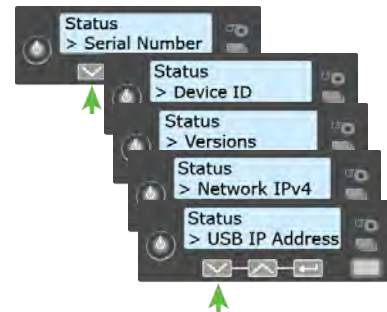

- f. Press ENTER to display the **Network IPv6** menu.

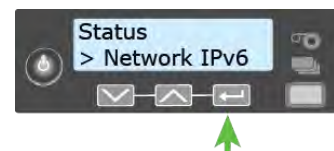

3. Press the down arrow until the address method used by your network displays on line 2.

- DHCP
- SLAAC
- Manual
- Local

Press ENTER to display the IP address.

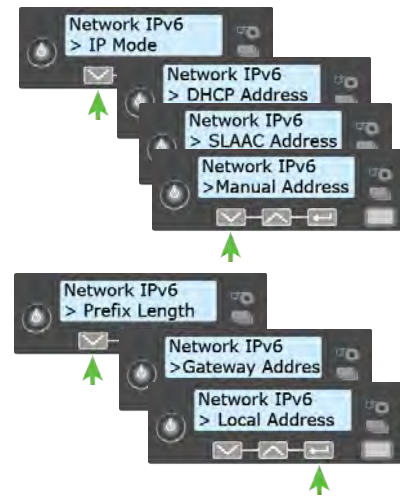

The example shows the LCD display for an IPv6 Manual address. DHCP, SLAAC, and Local addresses behave the same, as does the gateway address for a manual address.

An IPv6 address is represented as eight groups of four hexadecimal digits separated by colons. The address requires 39 characters to display. Because the LCD is limited to 16 characters per line, the IPv6 address is spread across three screens of the LCD. You can press either the down arrow or the ENTER key to display the next section of the address. A digit at the end of line 1 indicates which section of the address is being displayed.



A stateless (SLAAC) configuration (if enabled) can have multiple values depending on the router setup. The LCD displays up to four SLAAC addresses. An additional digit in line 1 indicates which address is being displayed.

4. Record the address.
5. Press the down arrow until **Exit** displays on line 2.
6. Press ENTER. Then, press the USER button to return the printer to **Ready**. The USER button glows green.

Print a Test Card

The printer includes a test card that prints without using a driver or other source of card data. Use it to verify that the printer is printing correctly. Make sure that cards are in the input hopper and all supplies are loaded before you begin. Refer to “[Load and Replace Supplies](#)” on [page 31](#) for complete information.

1. Begin with the printer **Ready**. The USER button shows steady green.
2. Press the USER button to display **Suspended** on line 1 of the LCD panel.
3. Press ENTER to enter the menu system.
4. Press ENTER to enter the Maintenance menu.
5. Press the down arrow until **Test Card** displays on line 2.
6. With **Test Card** displayed on line 2, press ENTER to display **Start** on line 2.
7. Press ENTER to print the test card.
After the card prints, the printer returns to **Ready**.

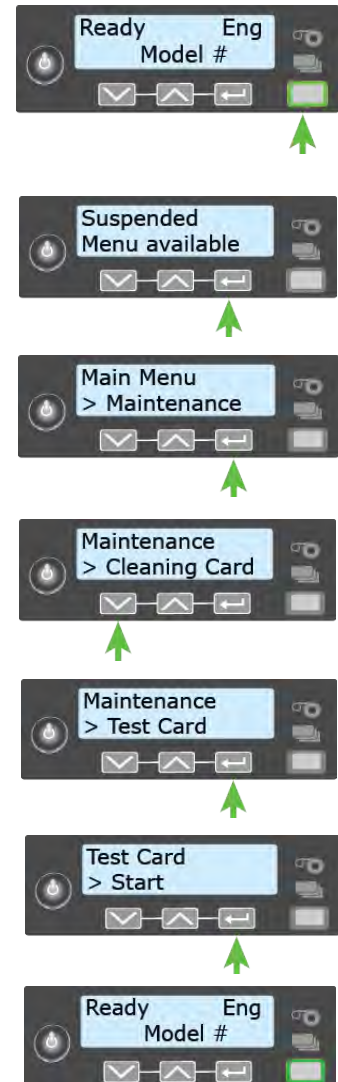

Select a Card Stock

The printer can have up to ten different card stocks defined. For example, one card stock might be used for a general ID card, while others are used for a retail card or a financial debit or credit card. Refer to the Printer Manager section of the printer's *Installation and Administrator's Guide* for more information about card stocks.

You can use the front panel menus to specify the card stock that is loaded in the input hopper or in each multi-hopper cartridge, or the card stock that will be inserted using the exception slot.

Do the following to select the card stock loaded in the input hopper.

1. Press the USER button to display **Suspended** on line 1 of the LCD panel.



2. Press ENTER to enter the menu system.

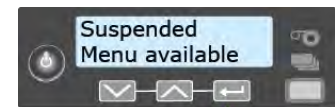

3. Press the down arrow to display **Configuration** on line 2.



4. Press ENTER to enter the **Configuration** menu.

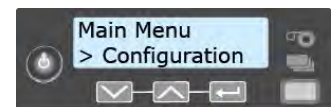

5. Press the down arrow until **Hopper** displays on line 2, and then press ENTER to display the **Hopper** menu.

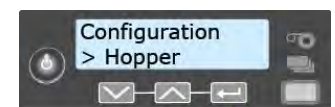

6. Press the down arrow until the correct hopper displays on line 2. You can specify a card stock for hoppers 1 through 6 in a multi-hopper printer.

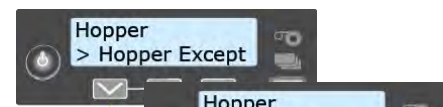

7. Press ENTER to select the card stock loaded in the input hopper.

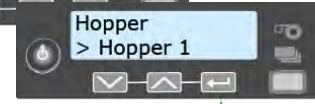

8. Press the down arrow until the card stock displays, and then press ENTER to save your selection.



Select a Color Mode

You can use the front panel menus to select the color mode that best defines the color printing requirements for your site. The color modes are calibrated and installed in the printer during manufacturing.

You also can select the color mode using Printer Manager. Refer to the printer's *Installation and Administrator's Guide* for more information about the color modes available.

Do the following to select the color mode.

1. Press the USER button to display **Suspended** on line 1 of the LCD panel.
2. Press ENTER to enter the menu system.
3. Press the down arrow to display **Configuration** on line 2.
4. Press ENTER to enter the **Configuration** menu.
5. Press the down arrow until **Color Mode** displays on line 2, and then press ENTER to display the **Color Mode** menu.
6. Press the down arrow until the color mode you want to use displays on line 2, and then press ENTER to save your selection.

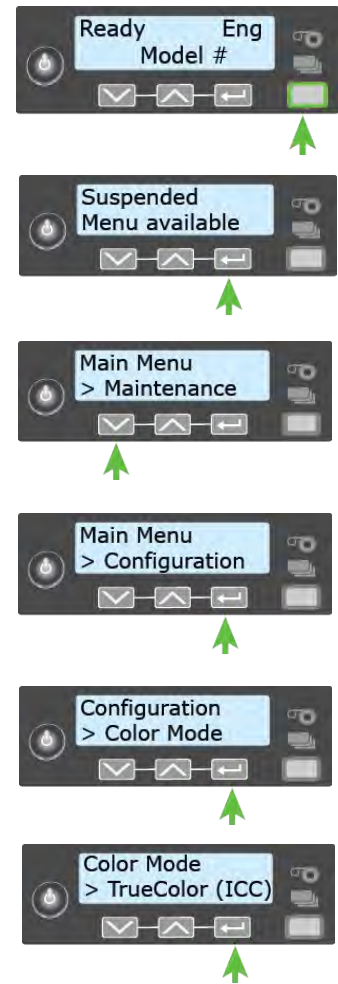

Load and Replace Supplies

To keep the printer ready to print cards, load blank card stock into the input hopper, load ink ribbon and retransfer film on the appropriate cartridges, and load a cleaning sleeve into the printer.



If your system includes the optional laminator, also load overlay material into the L1 and L2 (if equipped) laminators. Refer to [“Load Laminator Overlay Material”](#) on [page A-9](#), for information about loading the laminator cartridges.

Load Cards

Do the following to load cards in the input hopper. If you plan to insert cards manually using the exception slot, keep a supply of blank cards available.

- Handle cards by the edges only, or wear card inspection gloves approved by Entrust Datacard.
- Cards can stick together. Slide or fan the cards to separate the edges before placing them in the input hopper.
- Insert ISO magnetic stripe cards with the stripe (back side) facing down and to the right.
- Insert smart cards with the smart card chip facing up and toward the back of the hopper.



A diagram inside the input hopper shows the correct orientation for each type of card.

Single-Hopper Printer

1. Unlock the input hopper lock, if present, and open the input hopper door.
2. Load the cards into the input hopper. The hopper can hold up to 125 cards.
3. Close and lock the input hopper, if necessary.

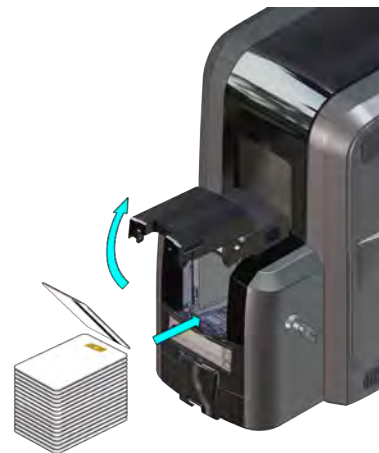

Use the Exception Slot

The exception slot allows you to insert a single card, such as a different card type than those loaded in the input hopper. The input hopper does not have to be opened to insert a card through the exception slot.

1. Slide the card into the exception slot.
2. Push the card all the way into the input hopper. The card slides under any cards already in the input hopper so that it can be picked.



Multi-Hopper Printer

Do the following to load cards into a multi-hopper cartridge.

1. Unlock the multi-hopper lock.
2. Slide the lock bar release button (B1) to the left to release the hopper lock bars.
3. Rotate a lock bar to the left to provide access to the multi-hopper input cartridge that you want to load.

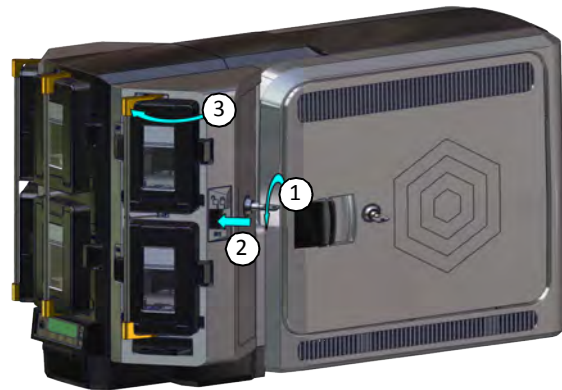

4. Press the cartridge release button at the top of the cartridge and open the cartridge door.
5. Lift the card weight to the top of the cartridge and gently pull it forward until it locks in position.
6. Load the cards into the input hopper cartridge.

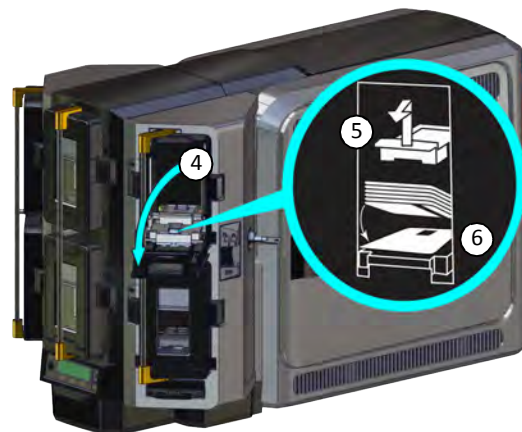



- The diagrams inside the cartridge show how to position the card weight and load cards. Do not place the cards on top of the card weight.
- You do not need to remove the cartridge from the multi-hopper.

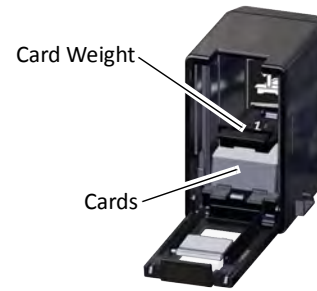

7. Close the cartridge door. This releases the card weight so that it is lowered on top of the cards.
8. Rotate the lock bar back into position.
9. Slide the lock bar release button to the right to lock the lock bars into place.
10. Lock the multi-hopper.



Caution: The lock bars, lock bar release button, and the multi-hopper door lock all must be in the lock position for the printer to operate. If any of the locks are left in the unlock position, the printer issues an error. You must unlock and re-lock all locks to clear the error and place the printer in **Ready** status.

Use the Multi-Hopper Exception Slide

Use the exception slide to insert a single card into the printer without unlocking the multi-hopper or opening a hopper cartridge.

1. Pull the exception slide out from the multi-hopper.
2. Insert the card into the exception slide tray.
3. Push the exception slide back into the multi-hopper.

The card is pulled into the printer to complete the job.

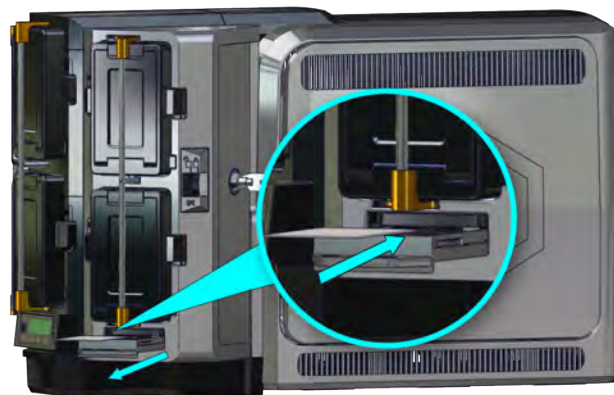

Replace the Ink Ribbon

Replace the ink ribbon when the ribbon runs out.

1. Unlock the printer, if necessary, and open the printer access door.
2. Press the ink ribbon cartridge release button and remove the blue ink ribbon cartridge (C1).
3. Place the cartridge on a flat surface with the spindles facing up.

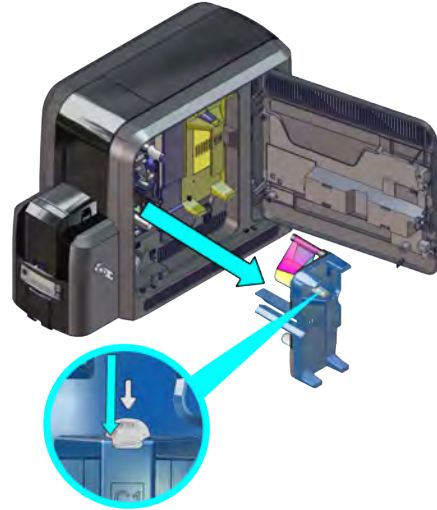

4. Remove both used spools from the cartridge.
 - a. Press the blue latch button and slide the used supply spool out from the cartridge.
 - b. Press the silver latch button and slide the full take-up spool out from the cartridge.
 - c. Follow your site's guidelines to properly discard the used ink ribbon.

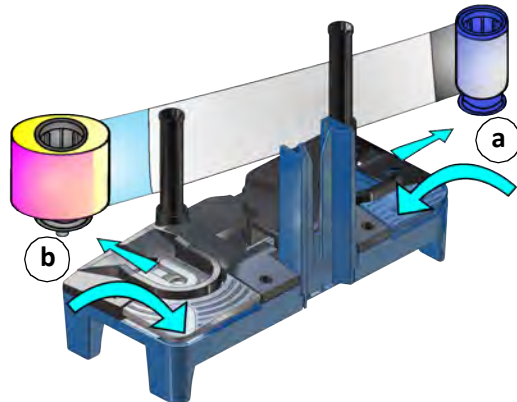

5. Clean the printer.

Each ink ribbon package contains an isopropanol cleaning card.

- a. Open the ink ribbon package and remove the cleaning card.
- b. Run the cleaning card through the printer. Refer to [“Clean the Printer”](#) on [page 47](#) for complete information about the cleaning process.

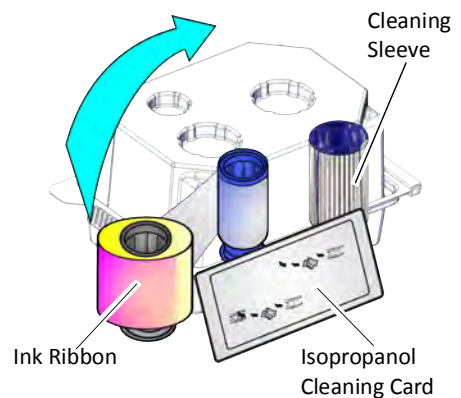

We recommend that you clean the printer after every 250 cards processed and each time you install a new ink ribbon. Refer to the [“Printer Cleaning Schedule”](#) on [page 46](#) for a complete schedule for cleaning the printer.

6. Remove the new ink ribbon from its package. Hold the ribbon cores and pull them up from the package base.



The package also includes a new cleaning sleeve. Refer to “Replace the Cleaning Sleeve” on page 36.

7. Install the ink ribbon.

- a. Slide the blue supply spool onto the cartridge until it clicks into place. The supply roll can go on only one way and fits only on the correct side of the cartridge.

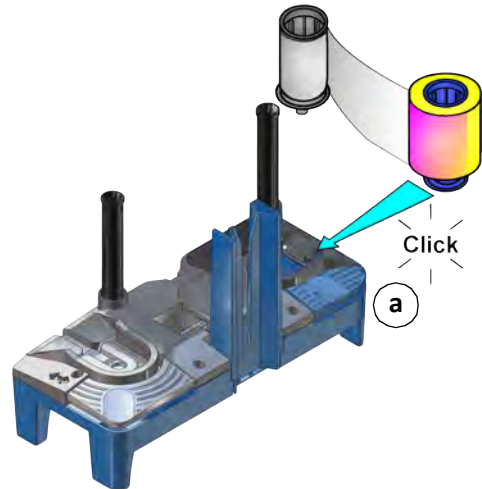

- b. Route the ink ribbon around the rollers on the cartridge. A diagram on the cartridge shows the correct routing pattern.

- c. Slide the empty silver take-up spool onto the cartridge until it clicks into place.

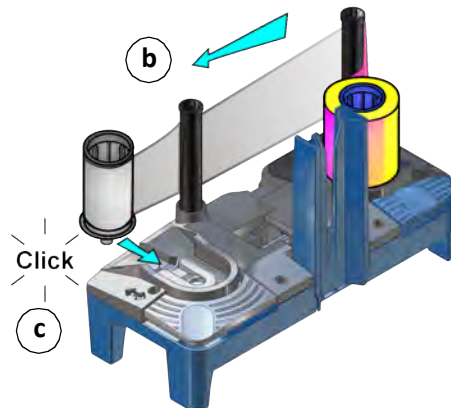

- d. Turn the take-up spool clockwise just enough to take up any slack in the ribbon.

8. Continue with “Replace the Cleaning Sleeve”.

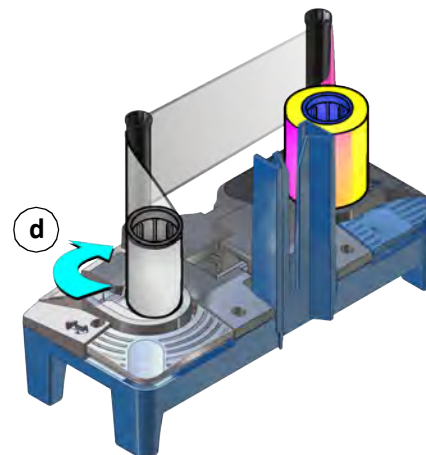

Replace the Cleaning Sleeve

The cleaning sleeve helps maintain print quality by removing dust and other particles from cards before they travel into the printer. Replace the cleaning sleeve each time you load a new ink ribbon. You also should replace the cleaning sleeve if you notice debris on the printed cards or if the cleaning sleeve is no longer sticky.

 You can access the cleaning sleeve when the ink ribbon cartridge is removed from the printer.

1. Remove the cleaning spindle from the printer.
 - a. Lift up the cleaning spindle handle (C3) and pull it straight out from the printer.
 - b. Remove the used cleaning sleeve from the cleaning spindle and discard it.
2. If you have not already done so, run a cleaning card through the printer. Refer to “Clean the Printer” on [page 47](#) for complete information about the cleaning process.
3. Load the new cleaning sleeve.
 - a. Slide the new cleaning sleeve onto the cleaning spindle.

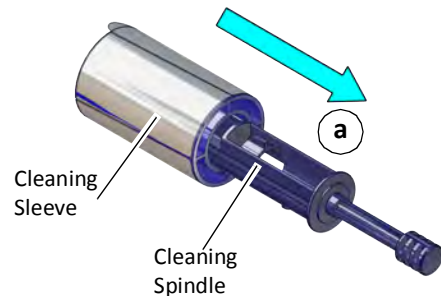
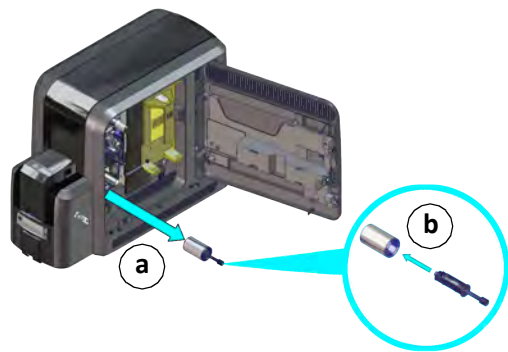

- b. Remove the protective wrapper from the cleaning sleeve.

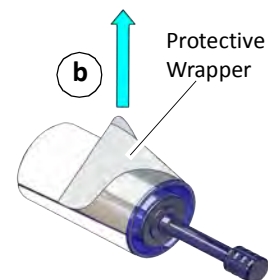

4. Replace the cleaning spindle in the C3 slot in the printer.

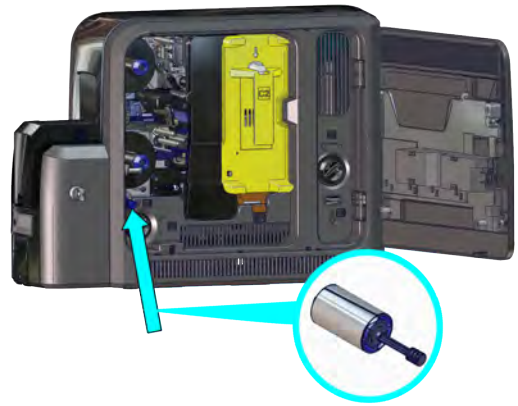

5. Replace the ink ribbon cartridge in the printer.

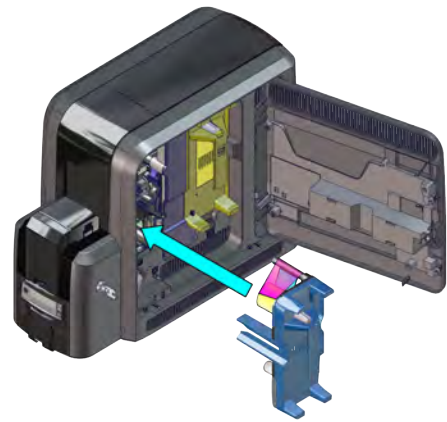

6. Close the printer access door and lock the printer, if necessary.

Replace the Retransfer Film

Replace the retransfer film when the film runs out.

1. Unlock the printer, if necessary, and open the printer access door.
2. Press the retransfer film cartridge release button and remove the yellow retransfer film cartridge (C2).
3. Place the cartridge on a flat surface with the spindles facing up.

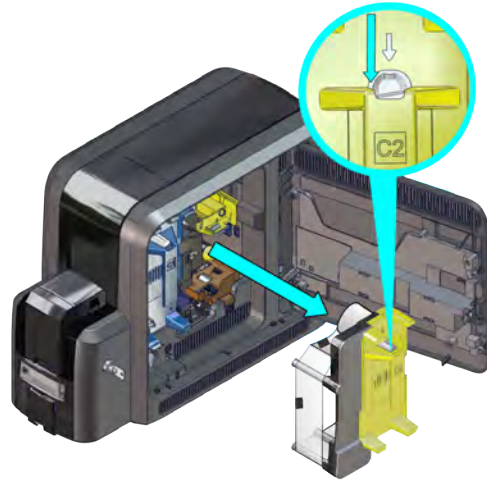

4. Remove both used spools from the cartridge.
 - a. Press the yellow latch button and slide the used supply spool out from the cartridge.
 - b. Press the silver latch button and slide the full take-up spool out from the cartridge.
 - c. Follow your site's guidelines to properly discard the used retransfer film.

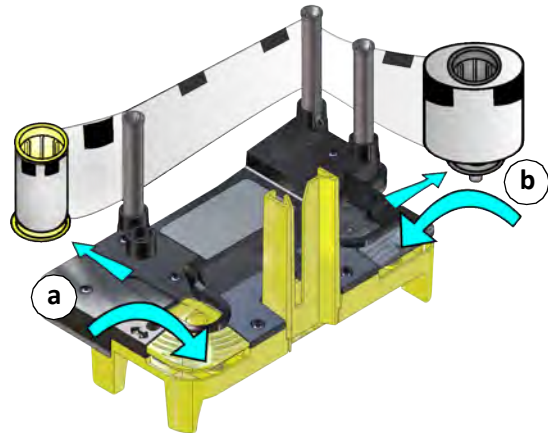

5. Remove the new roll of retransfer film from its package. Hold the film cores and pull them up from the package base.

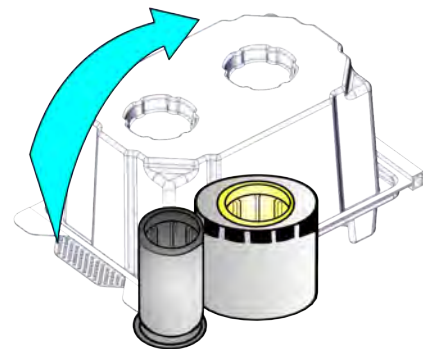

6. Install the retransfer film.

- a. Slide the yellow supply spool onto the cartridge until it clicks into place. The supply roll can go on only one way and fits only on the correct side of the cartridge.

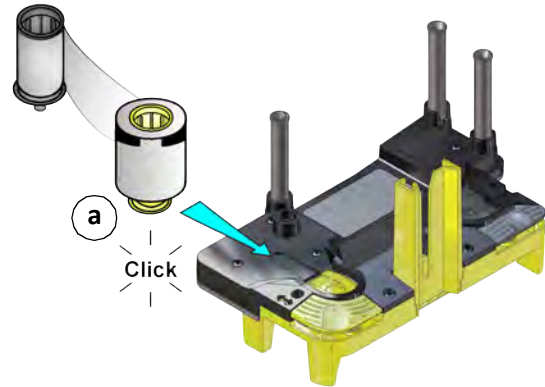

- b. Route the film around the rollers on the cartridge. A diagram on the cartridge shows the correct routing pattern.

- c. Slide the empty silver take-up spool onto the cartridge until it clicks into place.

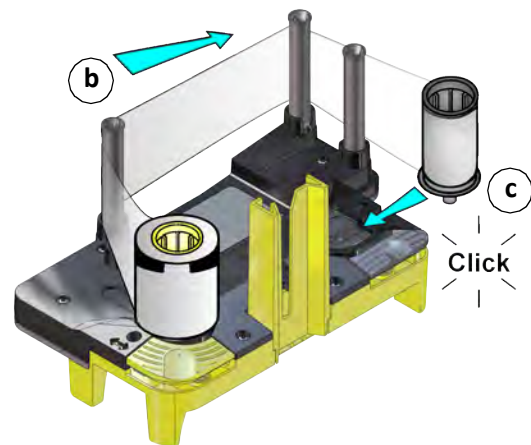

- d. Turn the take-up spool counterclockwise just enough to take up any slack in the film.

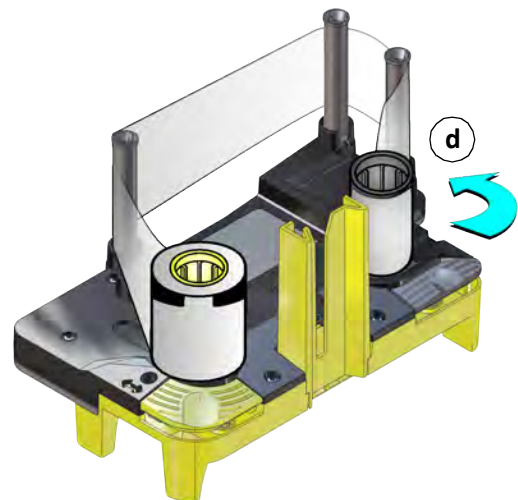

7. Remove any incomplete or rejected cards from the reject tray. Refer to “Empty the Printer Reject Tray” on [page 59](#) for more information.
8. Replace the retransfer film cartridge in the printer.
9. Close the printer access door and lock the printer, if necessary.

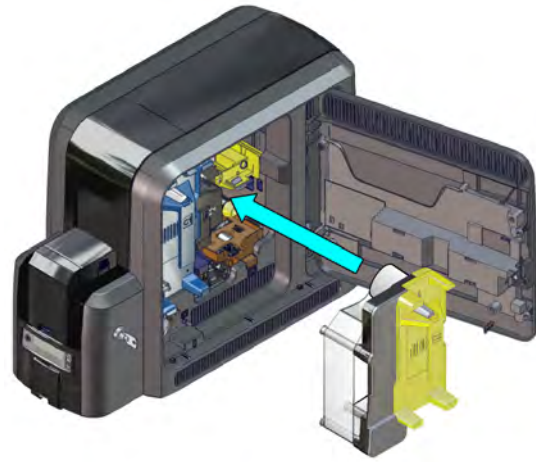

Chapter 4: Print Cards

4

This chapter provides an overview of how to use application software to prepare card designs and send card data to the printer.

Before You Begin

Before you start to print cards, make sure that you have met the following requirements:

- Cards are loaded in the printer, or available to insert.
- Ink ribbon and retransfer film are loaded. Refer to [“Replace the Ink Ribbon”](#) on [page 34](#) and [“Replace the Retransfer Film”](#) on [page 38](#). If your system includes the optional laminator, refer to [Appendix A: “CR805 Card Printer with Inline Lamination”](#) for information about preparing the laminator.
- The card design is set up. If you need to set up or modify the design, refer to [“Elements of Card Design”](#) in the printer’s *Installation and Administrator’s Guide*, and the documentation for your card personalization software.

You can use card personalization software, such as TruCredential software, to create and print card designs. The software handles the types of information used on cards and sends it to the printer. If you do not use ID software, you can use a retail PC application, such as Microsoft Word, with the XPS Card Printer Driver, to design and print the cards. With any application, make sure that you test each card design to verify that it is printing correctly and meets your requirements.

You also can:

- Print a test card directly from the printer. Refer to [“Print a Test Card”](#) on [page 28](#).
- Print a driver sample card. Refer to [“Print a Driver Sample Card”](#) in the *XPS Card Printer Driver User’s Guide*.

Print Cards from ID Software

Do the following to print cards from ID software. Refer to your application's documentation for detailed instructions about how to set up a card design and enter the card data.

1. Select a template or design for the card.
2. Enter the data for the card. Follow the instructions for your software.
3. Capture a photo for the card, if necessary.
4. Select the printer, if you use more than one printer.
5. Click the **Print** button to send the card to the printer.
6. At the printer, insert a card into the printer, if necessary.

Print Cards from Other Software

The following example illustrates how you can use Microsoft Word with the Card Printer Driver to design and print a card. Refer to the *XPS Card Printer Driver User's Guide* for complete information about how to set up the XPS Card Printer Driver to print a card from the application.

1. Open Microsoft Word and select **File > Print**.
2. Select the card printer as the current printer.

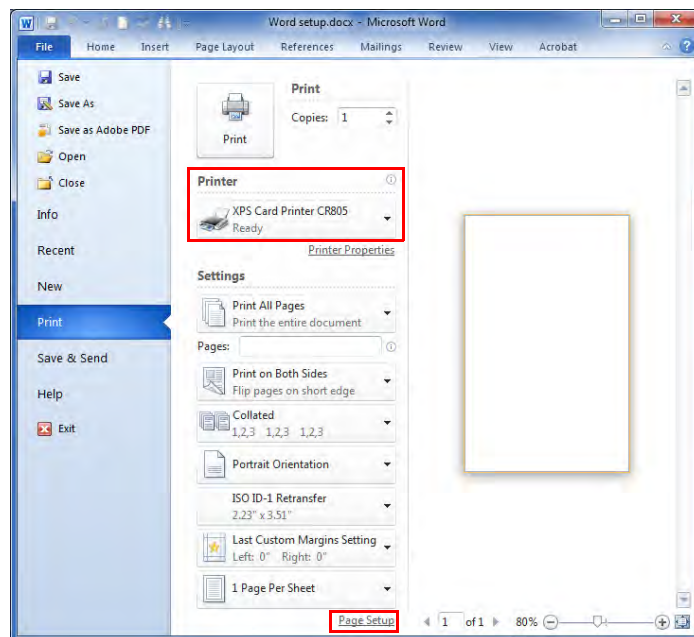

3. Click **Page Setup** and select **ISO ID-1 Retransfer** as the paper size, or set the paper size to 2.23 x 3.51 in. (The ISO ID-1 Retransfer paper size becomes available after you select the card printer.)

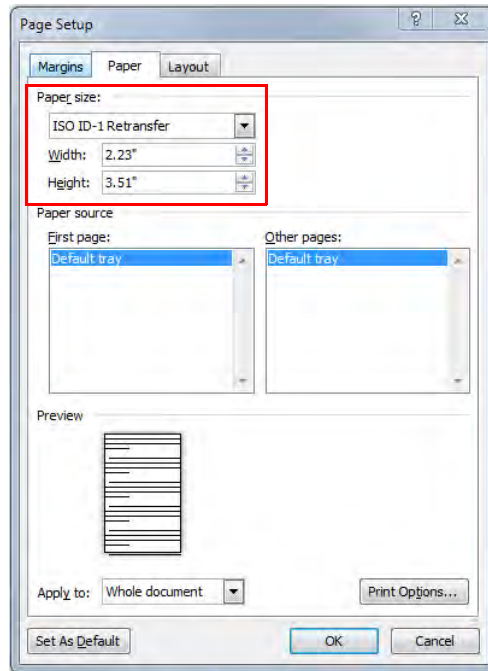

4. Set the margins to 0 (zero).
5. Select an orientation—either **Portrait** or **Landscape**.

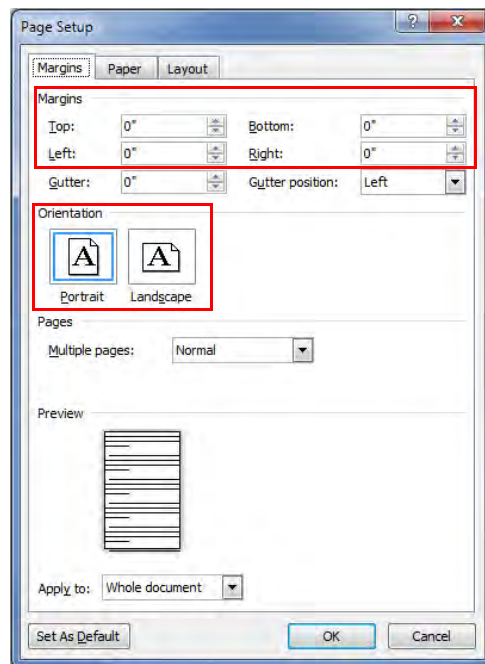

6. Create the card design:

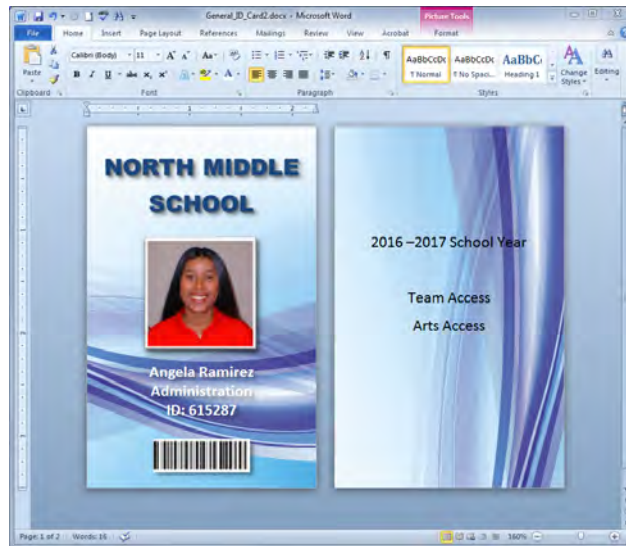

- a. Add graphics, such as a company logo or background.
- b. Add a photo.
- c. Add text information, such as name, address, or employee number.

For information about additional card features, refer to “Elements of Card Design” in your printer’s *Installation and Administrator’s Guide*.

- 7. Click **Print** to send the card to the printer.
- 8. At the printer, insert a card into the printer, if necessary.



Chapter 5: System Maintenance

5

This chapter provides information to help you maintain your printer for optimal performance.

Maintain the Printer

The printer performs best when it is cleaned on a regular basis. Follow the cleaning guidelines for your site to keep the printer in good working condition. Refer to the “[Printer Cleaning Schedule](#)” on [page 46](#) for cleaning best practices.

You can perform the following tasks to maintain the printer:

- [Clean the Printer on page 47](#)
- [Clean the Printhead Cam Rollers on page 56](#)
- [Clean the Printhead on page 57](#)
- [Empty the Printer Reject Tray on page 59](#)

If your printer system includes a laminator, refer to “[Empty the Laminator Reject Tray](#)” on [page A-11](#).

If your printer system includes the optional laminator, refer to “[Clean the Laminator](#)” on [page A-12](#) for information about cleaning the laminator.

Printer Cleaning Schedule

The following schedule describes the recommended cleaning intervals for the printer. Follow this schedule to maintain the printer and obtain the best print quality.



The type of card stock you use and the printer environment can affect how often you need to perform the cleaning procedures.

Schedule	Action	Procedure
Every 250 cards	Clean the printer with the isopropanol cleaning card. Note: You do not need to remove the ink ribbon and retransfer film cartridges from the printer.	Refer to “Use the Isopropanol Cleaning Card” on page 48.
When you change the ink ribbon	Clean the printer with the isopropanol cleaning card. Note: Remove the ink ribbon and retransfer film cartridges from the printer.	Refer to “Use the Isopropanol Cleaning Card” on page 48.
	Replace the cleaning sleeve (C3).	Refer to “Replace the Cleaning Sleeve” on page 36.
If you see particles on completed cards	Replace the cleaning sleeve (C3).	Refer to “Replace the Cleaning Sleeve” on page 36.
	Clean the printer with the adhesive cleaning card. Note: Remove the ink ribbon and retransfer film cartridges from the printer.	Refer to “Use the Adhesive Cleaning Card” on page 51.
If you see repeating color dots on completed cards	Clean the printhead cam rollers.	Refer to “Clean the Printhead Cam Rollers” on page 56.
If you see color or white lines on completed cards	<ul style="list-style-type: none"> Clean the printhead using the cleaning swab. If print quality continues to diminish, clean the printhead using the lapping stick. 	Refer to the “Clean the Printhead” on page 57



If your printer includes a rear fan filter, clean the filter every three months.
Note: The rear fan filter is not present in all printer models. If the filter is present, refer to your printer’s *User’s Guide* for cleaning instructions.

Clean the Printer

The cleaning sleeve removes dust and particles from cards before they enter the printer. However, you also need to clean the inside of the printer regularly to maintain print quality. The cleaning cards remove debris from the inside of the printer and from the transport rollers.

Two different cleaning cards are available to clean the printer:

- A double-sided, isopropanol cleaning card. An isopropanol cleaning card is included in each ink ribbon package.
- A double-sided, adhesive cleaning card that removes particles that result from the retransfer process. Use the card if you notice diminished print quality, such as a repeating pattern of spots on the card. Refer to [“Print quality concerns”](#) on [page 72](#) for additional print quality information.



The cleaning cards may become bowed slightly during shipment. If a card is bowed, insert the card into the printer as shown.

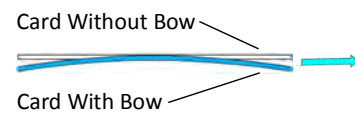

Clean the printer:

- After every 250 cards processed. Use the isopropanol cleaning card.
- Each time you install a new roll of ink ribbon. Refer to [“Replace the Ink Ribbon”](#) on [page 34](#). Use the isopropanol cleaning card.
- If you notice particles on completed cards, or if print quality diminishes. Use the adhesive cleaning card.

You might need to run a cleaning card more often depending on your environment.



If the printer is located in a dusty environment and will be stored for a long period of time (for example, several months), turn off the printer and cover it with the plastic shipping bag to keep dust and other debris out of the printer.

Keep additional cleaning supplies on hand to clean the printer when needed. Refer to the printer’s *Installation and Administrator’s Guide* to order additional cleaning supplies.

Use the following procedures to clean the inside of the printer. Refer to the [“Printer Cleaning Schedule”](#) on [page 46](#) for cleaning best practices.

- [Use the Isopropanol Cleaning Card on page 48](#)
- [Use the Adhesive Cleaning Card on page 51](#)

Use the Isopropanol Cleaning Card

Use the isopropanol cleaning card regularly to clean the printer.



If you are cleaning the printer when replacing the ink ribbon, remove both the ink ribbon and retransfer film cartridges and run the cleaning card with the supplies out of the printer. This allows the printer to perform a recalibration procedure as part of the cleaning process. Refer to [“Replace the Ink Ribbon”](#) on page 34 and [“Replace the Retransfer Film”](#) on page 38 for more information.

1. Remove the isopropanol cleaning card from the ink ribbon container.
2. Open the isopropanol cleaning card package and remove the card.

Clean the printer immediately. The cleaning card dries out if it is out of its package for more than a few minutes.

3. Continue with:
 - [Single-Hopper Printer](#)
 - [Multi-Hopper Printer](#) on page 49

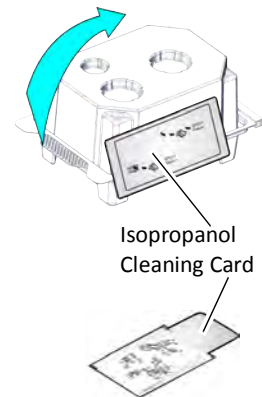

Single-Hopper Printer

1. Power on the printer, if necessary.
2. Unlock the input hopper lock, if present.
3. Open the input hopper cover.
4. Remove any unprinted cards. Handle the cards by the edges only, or wear card inspection gloves approved by Entrust Datacard.



5. Load the cleaning card into the input hopper.
If the cleaning card appears bowed, insert it as shown.

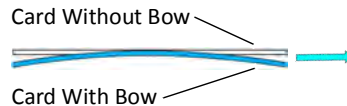

6. Close and lock the input hopper, if necessary.
7. Continue with [“Run the Isopropanol Cleaning Card”](#).



Multi-Hopper Printer

1. Power on the printer, if necessary.
2. Pull out the multi-hopper exception slide and insert the cleaning card.

If the cleaning card appears bowed, insert it as shown.

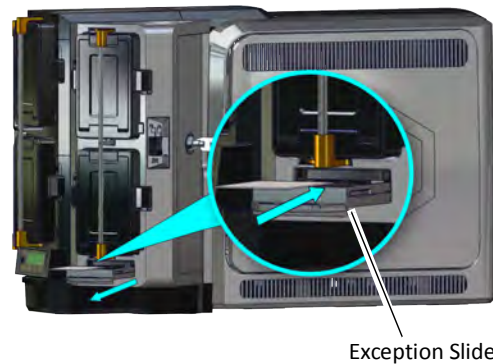
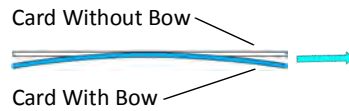

3. Push in the exception slide.
4. Continue with “Run the Isopropanol Cleaning Card”.

Run the Isopropanol Cleaning Card

Use the LCD menu system to run the isopropanol cleaning card.

1. Begin when the printer displays **Ready** and the USER button shows steady green. Press the USER button.
2. **Suspended** displays on line 1 of the LCD panel. Press ENTER to enter the menu system.
3. **Maintenance** displays on line 2 of the LCD panel. Press ENTER to enter the **Maintenance** menu.
4. **Cleaning Card** displays on line 2 of the LCD panel. Press ENTER to enter the **Cleaning Card** menu.
5. **Isopropanol** displays on line 2 of the LCD panel. Press ENTER to select the isopropanol cleaning card.

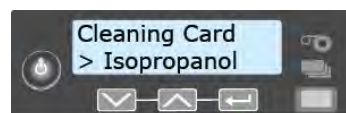
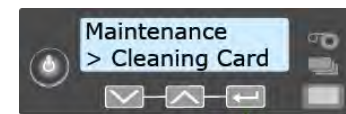
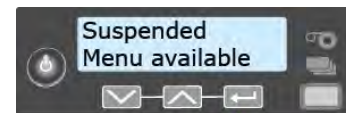

6. **Start** displays on line 2 of the LCD panel. Press ENTER to start the cleaning process.

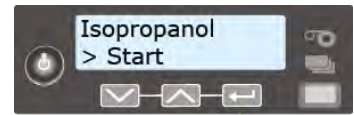

7. **Insert cleaning card** displays on the LCD panel. Press the USER button to start the cleaning cycle.

The printer moves the card through the printer several times. If the vertical transport is installed, the card moves into the transport area and cleans the rollers located there.

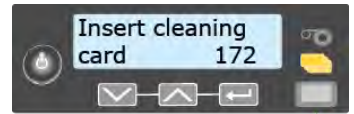

When the cleaning cycle completes:

- **If the printer does not have locks:** The isopropanol cleaning card is ejected into the output hopper. Remove and discard the cleaning card.
- **If the printer has locks:** The isopropanol cleaning card is placed in the printer reject tray (RT1). It can remain in the reject tray until the next time the tray is emptied.



When you clean a system with a laminator, the isopropanol cleaning card moves into the laminator after cleaning the printer and cleans the laminator rollers and card entry area. The cleaning card is ejected into the laminator output hopper or the laminator reject tray. If necessary, open the laminator to remove the cleaning card.

8. Continue with [“Prepare the Printer for Use”](#) on page 54.

Use the Adhesive Cleaning Card

Use the adhesive cleaning card to remove particles that result from the retransfer process. Refer to the “[Printer Cleaning Schedule](#)” on [page 46](#) for information about when to use the adhesive cleaning card.



Remove the ink ribbon and retransfer film cartridges and run the adhesive cleaning card with the supplies out of the printer. This prevents the cleaning card from sticking to the ink ribbon or retransfer film, and allows the printer to perform a recalibration procedure as part of the cleaning process.

Single-Hopper Printer

1. Power on the printer, if necessary.
2. Remove the ink ribbon and retransfer film cartridges. Refer to “[Replace the Ink Ribbon](#)” on [page 34](#) and “[Replace the Retransfer Film](#)” on [page 38](#).
3. Unlock the input hopper lock, if present.
4. Open the input hopper cover.
5. Remove any unprinted cards. Handle the cards by the edges only, or wear card inspection gloves approved by Entrust Datacard.
6. Peel off the center strips on both sides of the adhesive cleaning card. Leave the side strips in place.



7. Load the adhesive cleaning card in the input hopper.
If the cleaning card appears bowed, insert it as shown.

Peel Off Center Strips Only

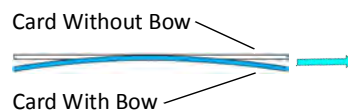
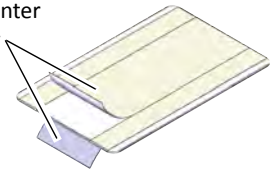

8. Close the input hopper and lock the printer.
9. Continue with “[Run the Adhesive Cleaning Card](#)” on [page 53](#).



Multi-Hopper Printer

1. Power on the printer, if necessary.
2. Remove the ink ribbon and retransfer film cartridges. Refer to [“Replace the Ink Ribbon”](#) on page 34 and [“Replace the Retransfer Film”](#) on page 38.
3. Unlock the multi-hopper.
 - a. Unlock the multi-hopper door lock (a).
 - b. Slide the lock bar release button (B1) to the left to release the hopper lock bars (b).
 - c. Rotate the center lock bar to the left to provide access to the H2 and H5 multi-hopper input cartridges (c).

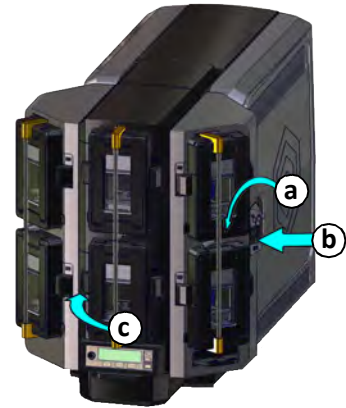

4. Press the cartridge release button at the top of the H2 cartridge and open the cartridge door (d).
5. Lift the card weight to the top of the cartridge and gently pull it forward until it locks in position (e).
6. Remove the unprinted cards from the H2 cartridge (f). Handle the cards by the edges only, or wear card inspection gloves approved by Entrust Datacard.

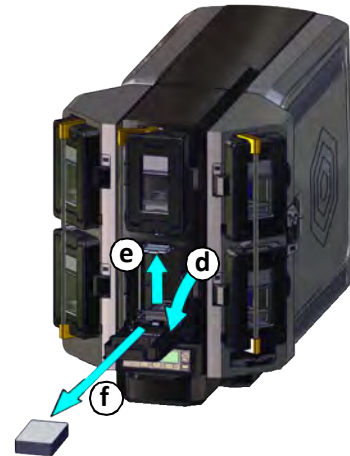

7. Peel off the center strips on both sides of the adhesive cleaning card. Leave the side strips in place.

Peel Off Center Strips Only

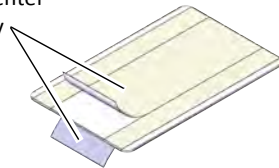

8. Load the adhesive cleaning card in the H2 cartridge and close the cartridge door (g).

If the cleaning card appears bowed, insert it as shown.

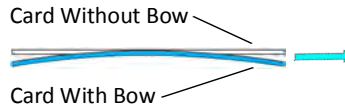

Caution: Do not insert the adhesive cleaning card in the exception slide of the multi-hopper.

9. Lock the multi-hopper.
 - a. Rotate the center lock bar to the right to the lock position.
 - b. Slide the lock bar release button to the right to lock the lock bars into place.
 - c. Lock the multi-hopper door lock.
10. Continue with “Run the Adhesive Cleaning Card”.

Run the Adhesive Cleaning Card

Use the LCD menu system to run the adhesive cleaning card.

1. Begin when the printer displays **Ready** and the USER button shows steady green. Press the USER button.
2. **Suspended** displays on line 1 of the LCD panel. Press ENTER to enter the menu system.
3. **Maintenance** displays on line 2 of the LCD panel. Press ENTER to enter the **Maintenance** menu.
4. **Cleaning Card** displays on line 2 of the LCD panel. Press ENTER to enter the **Cleaning Card** menu.
5. **Isopropanol** displays on line 2 of the LCD panel. Press the down arrow.

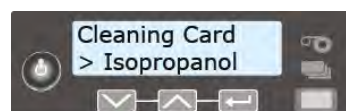
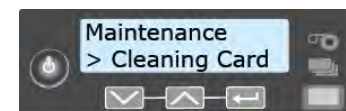
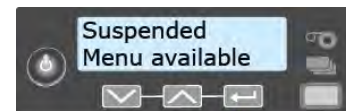

6. **Adhesive** displays on line 2 of the LCD panel. Press ENTER to select the adhesive cleaning card.

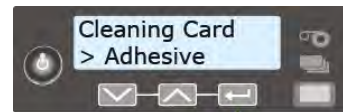

7. **Start** displays on line 2 of the LCD panel. Press ENTER to start the cleaning process.

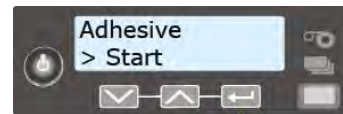

8. The **Insert cleaning card** message displays on the LCD panel. Press the USER button to start the cleaning cycle.

Single-Hopper Printer

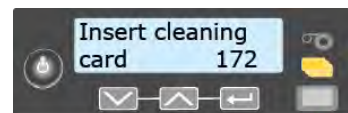

Multi-Hopper Printer

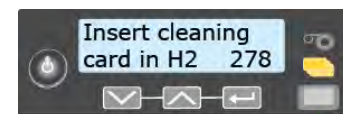

The printer moves the card through the printer several times. If the vertical transport is installed, the card moves into the transport area and cleans the rollers located there.

At the end of the cleaning cycle, the adhesive cleaning card is ejected into the printer reject tray (RT1).



When you clean a system with a laminator, the adhesive cleaning card moves into the laminator after cleaning the printer and cleans the laminator rollers and card entry area. The cleaning card is ejected into the laminator reject tray. Open the laminator to remove the cleaning card.

9. Continue with [“Prepare the Printer for Use”](#).

Prepare the Printer for Use

1. If you removed the ink ribbon and retransfer film cartridges:
 - a. Unlock the printer, if necessary, and open the printer access door.
 - b. Remove the used cleaning card and any rejected cards from the printer reject tray (RT1). Refer to [“Empty the Printer Reject Tray”](#) on [page 59](#).
2. Install a new cleaning sleeve, if necessary. Refer to [“Replace the Cleaning Sleeve”](#) on [page 36](#) for the steps to follow.
3. Load a new ink ribbon, if necessary. Refer to [“Replace the Ink Ribbon”](#) on [page 34](#) for more information.
4. Replace the ink ribbon and retransfer film cartridges and close the printer access door.

5. Replace the cards in the input hopper of a single-hopper printer, or the H2 cartridge of a multi-hopper printer. Refer to “Load Cards” on page 31.
6. Lock the printer, if necessary.
7. Press the USER button to return the printer to **Ready** and make it available to print cards again.
8. Discard the used cleaning card and cleaning sleeve.



HINTS & TIPS

- Use each cleaning card one time only.
- Replace the cleaning sleeve, as needed. Refer to the “Printer Cleaning Schedule” on page 46 for the replacement schedule.



If the card light is blinking amber and there are cards in the input hopper, the printer’s configured cleaning count has been reached and it is time to clean the printer. The number of cards between cleaning is set in the Printer Manager **FrontPanel** settings. Refer to the printer’s *Installation and Administrator’s Guide* for complete information about using Printer Manager.

Clean the Printhead Cam Rollers

Use the adhesive cleaning card to clean the printhead cam rollers. Refer to the “[Printer Cleaning Schedule](#)” on [page 46](#) for information about when to clean the cam rollers.

1. Power off the printer, if necessary.
2. Unlock the printer, if necessary, and open the printer access door.
3. Remove the retransfer film cartridge (C2) from the printer.

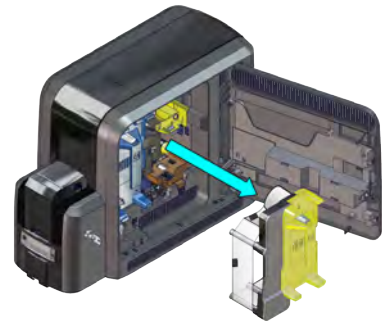

4. Peel off the center and both side strips from one side of the adhesive cleaning card.

Peel Off Center and Both Side Strips

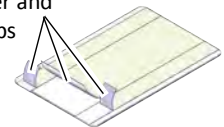

5. Insert the cleaning card vertically into the printer between the retransfer cartridge guidepost and the rollers. Make sure that the adhesive side of the card faces to the right and touches the rollers.

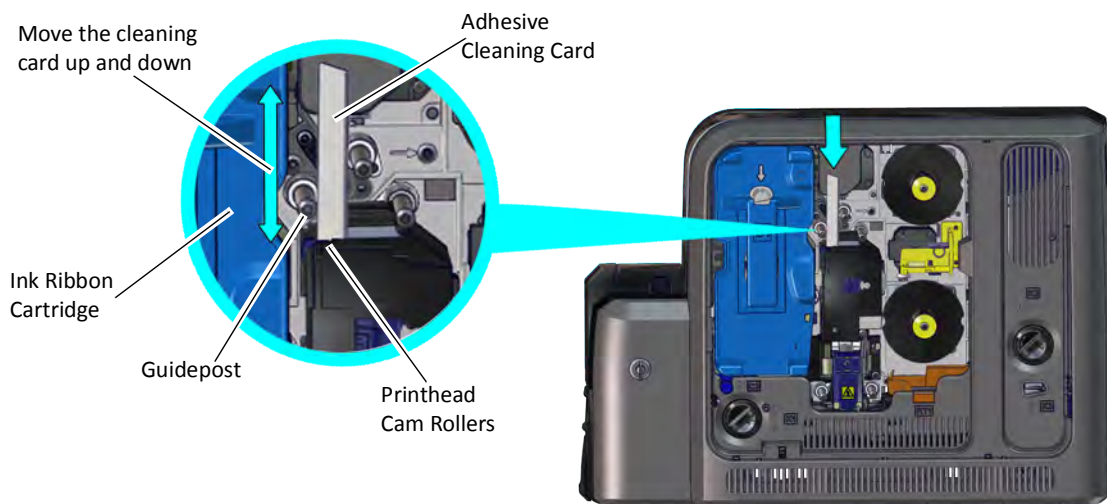

6. Move the cleaning card up and down along the rollers to remove debris.
7. Replace the retransfer film cartridge and close and lock the printer.
8. Discard the used cleaning card.

Clean the Printhead

Clean the printhead in the following situations:

- If there are unprinted lines on the finished card. This may indicate dirt or contaminants on the printhead.
- The printhead is touched accidentally. Oils from hands can affect print quality and damage the printhead.

Use a Cleaning Swab

1. Power off the printer.
2. Unlock the printer, if necessary, and open the printer access door.
3. Remove the ink ribbon and retransfer film cartridges.
4. Open and remove a cleaning swab from its package.
5. Using gentle pressure, move the cleaning swab back and forth along the full length of the heater line on the printhead.

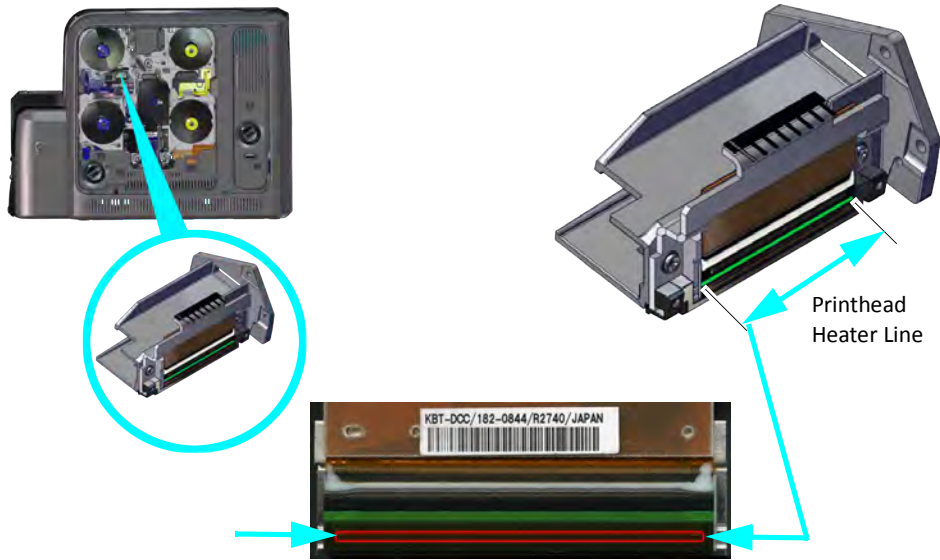
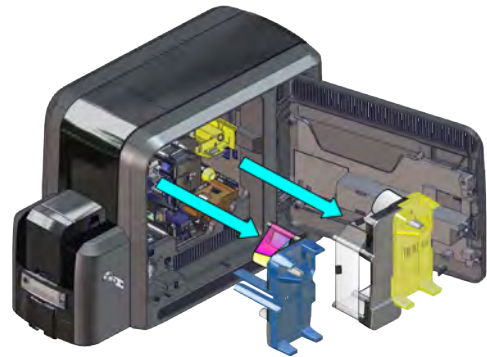

6. Replace the ink ribbon and retransfer film cartridges.
7. Close the printer access door and lock the printer, if necessary.
8. Power on the printer.
9. Print a sample card to verify the quality of printing. Refer to “Print a Test Card” on page 28 for more information.

Use a Lapping Stick

If the print quality does not improve after using the cleaning swab, clean the printhead using a lapping stick.

1. Repeat [step 1](#) through [step 3](#) on [page 57](#).
2. Open and remove the lapping stick from its package.



Do not remove the pink lapping paper from the lapping stick.

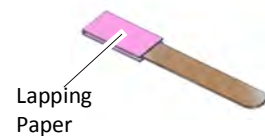

3. Repeat [step 5](#) on [page 57](#) using the lapping stick.
4. Open a new cleaning swab and repeat [step 5](#) again to remove any leftover debris loosened by the lapping stick from the printhead.
5. Repeat [step 6](#) through [step 9](#) to complete the cleaning process.

HINTS & TIPS

- Avoid touching the heater line of the printhead with your fingers. Contamination due to skin oils eventually can damage the printhead.
- Avoid touching the heater line of the printhead with any sharp objects that can permanently damage the printhead.
- Use only the cleaning swab and lapping stick to clean the printhead. Other materials can stick to the printhead and cause damage.
- Use the lapping stick and each cleaning swab one time only. Discard the materials after you clean the printhead.

Empty the Printer Reject Tray

The printer places rejected cards (unfinished cards or cards that were not processed properly) in the reject tray. You should empty the reject tray whenever the retransfer film is replaced, or more often depending on your procedures. Error message 242, “RT1 reject tray full,” displays on the LCD panel when the reject tray is full.

1. Unlock the printer, if necessary, and open the printer access door.
2. Remove the retransfer film cartridge from the printer.

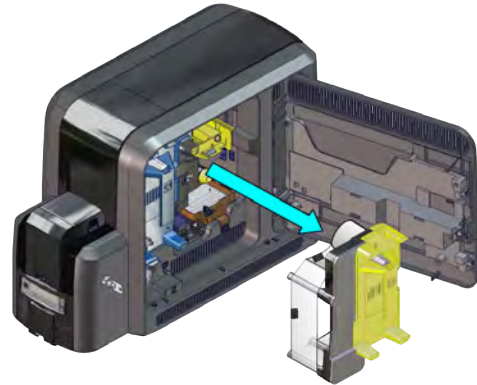

3. Remove the rejected cards from the reject tray.



You do not need to remove the reject tray from the printer. You can access the cards in the tray when the retransfer cartridge is removed.

4. Replace the retransfer film cartridge in the printer.
5. Close the printer access door and lock the printer.

Follow your organization’s procedures to track the cards removed and to dispose of them properly.

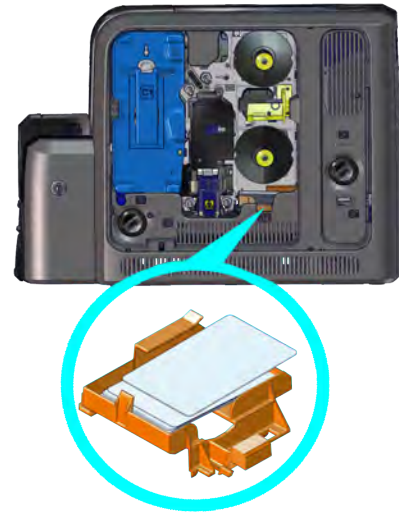

If your system includes a laminator, the printer reject tray is not used. Cards are placed in the laminator reject tray. Refer to “Empty the Laminator Reject Tray” on page A-11.



Chapter 6: Troubleshooting



This chapter provides information to help you respond to card printer messages. It also explains how to clear card jams and how to recover from other errors.

This section helps you identify and fix basic issues that can occur during printing. Also refer to the *XPS Card Printer Driver User's Guide* for additional troubleshooting information.

The section starts with an overview of card production and printer issues you may encounter:

- [Locate a Problem Within the Card Production System on page 62](#)
- [Locate a Problem with Basic Printer Functions on page 63](#)

This section also describes troubleshooting for the following:

- [Installation Problems on page 64](#)
- [Card Printer Driver Problems on page 66](#)
- [Card Appearance on page 69](#)
- [Magnetic Stripe Troubleshooting on page 75](#)
- [Laminator Troubleshooting on page 77](#)
- [Printer Card Jams on page 80](#)
- [Repair a Broken Ink Ribbon or Retransfer Film on page 83](#)
- [Messages and Conditions on page 84](#)
- [Respond to Messages on page 89](#)

Locate a Problem Within the Card Production System

For typical components of the system, refer to “[Printer Overview](#)” on [page 17](#). If any one of the following components does not work properly, printing cards can be affected.

- The XPS Card Printer Driver

If you need to reinstall the Card Printer Driver to fix a problem, we recommend you download the latest version of the driver from <https://www.entrustdatacard.com>. Click the Menu icon and select **Resource Center > Drivers & Downloads**. Click **Go Now**. Enter your printer model in the **Enter product name or number** field, and click **Go**.

- Card production software

Card production software formats the types of data used to print cards. Make sure that the card production software features you use work with your printer.

If you do not use card production software, make sure that the software you use supports the requirements for creating cards. If you use magnetic stripe data, use an application that saves text as text and not as a graphic. (For example, Microsoft Paint only saves graphic data, but Adobe Photoshop saves both graphic and text data.) Card Printer Driver fonts and escapes require that text is sent from the application as text.

- Other components of the system

An ID or badge system usually includes a camera to take photos, and may include other capture devices for biometric data. The proper use and maintenance of these components is important to the quality of cards you produce.

Locate a Problem with Basic Printer Functions

If the system is not working as expected, follow these steps in the order listed to isolate the source of the problem before you contact your service provider.

1. Make sure that the power cord is plugged in and the printer is powered on.
2. Does the printer power on and display **Ready** on the front panel within one minute?
 - If the printer powers on correctly, continue to step 3.
 - If the printer powers on, but **Improper Shutdown** displays on the LCD panel, press the **USER** button for approximately two seconds. **Ready** should display.
 - If the printer powers on but does not display **Ready**, the printer is not working properly. Request service for the printer.
 - If the printer does not power on, make sure that the printer power supply is working properly. A light on the power supply indicates that it is functioning.
 - ◆ If the power supply is working properly, request service for the printer from your system administrator.
 - ◆ If the power supply is not functioning, replace it and begin with step 1.
3. Print a test card. Refer to [“Print a Test Card”](#) on [page 28](#) for more information.
 - If the test card prints, the printer is working correctly. Continue to step 4.
 - If the test card does not print, the printer is not working correctly. Request service for the printer.
4. Connect the printer data cable, if necessary. Make sure that you use the same type of cable (USB or network) used when the printer was installed.
5. If you use the XPS Card Printer Driver, print a driver sample card. For the steps to follow, refer to the *XPS Card Printer Driver User’s Guide*.
 - If the sample card prints, the printer and driver are communicating correctly. Continue to step 6.
 - If the sample card does not print, the printer and driver have a communication problem. Determine the cause of the problem and try the sample card again.

If you do not use the Card Printer Driver, ask your service provider or software provider for assistance.

6. Print a card using your card production software.
 - If the card prints, your software is working successfully with the printer. Troubleshoot the card design, if necessary.
 - If the card does not print, check the following:
 - ◆ Is the correct printer selected in the Print Setup or Print dialog box of the application?
 - ◆ If the printer produced a blank card, review the page size or other settings.

If the card causes an error, the card might have a type of data the printer does not support.

Installation Problems

This section describes issues that prevent a successful installation and provides recommended solutions to those issues. Select from the following topics:

- [USB Installation Troubleshooting on page 65](#)
- [Network Installation Troubleshooting on page 66](#)

USB Installation Troubleshooting

Problem	Solution
The cable is loose.	Reconnect the USB cable to the ports on the PC and the printer. Power the printer off, and then back on. If the PC and printer still do not communicate, restart the PC.
The data cable is damaged or frayed.	Power off the printer. Replace the cable if you have a spare. Contact your service provider to order a new data cable.
The system has a temporary communication problem.	Check for the following: <ul data-bbox="638 678 1364 856" style="list-style-type: none"><li data-bbox="638 678 1364 779">• USB extension cables can cause communication problems. The recommended USB cable is 6-ft. (2 meters) long. Make sure that the cable is rated for USB 2.0 data transmission.<li data-bbox="638 789 1364 856">• If you are using a USB hub, a self-powered hub is recommended.
The PC USB port does not communicate with the printer USB port.	Power management on the PC has shut down USB communication. Check the following: <ul data-bbox="638 968 1364 1262" style="list-style-type: none"><li data-bbox="638 968 1364 1068">• Open Device Manager and the list of USB devices. Disable shutdown for each hub in the list. Restart the PC to make the changes take effect, if necessary.<li data-bbox="638 1079 1364 1180">• Hibernation on a laptop requires several moments to enable USB communication. Unplug the USB printer port and then connect it again.<li data-bbox="638 1190 1364 1262">• Replace the PC port or the PC. Contact your PC or port vendor if you need assistance.

Network Installation Troubleshooting

Problem	Solution
The network cable is loose.	Reconnect the data cable to the network port and the printer. Restart the printer.
The Status page of Printer Properties shows the printer is not available, but the printer displays Ready on the LCD panel.	Follow your network troubleshooting procedures to isolate and test each component of the computer-to-printer communication link. Suggestions: <ul style="list-style-type: none">• Verify the computer-to-network connection by accessing a network resource, such as a network drive.• The network administrator can test communication between a server and the printer.• Make sure that the user is logged on to the network.
The printer is not configured with the correct network address	Make sure that the server name or IP address is entered in the Port Settings or Configure Port dialog box on the computer. For more information about retrieving the printer's IP address, refer to "Retrieve the Printer's Network IP Address" on page 23 . Make sure that Ready displays on the printer's LCD panel.

Card Printer Driver Problems

The Card Printer Driver and printer can have the following communication problems:

- [The Card Printer Driver does not detect the network-connected printer on page 67.](#)
- [The Card Printer Driver does not detect the USB-connected printer on page 67.](#)
- [Driver status or Windows print queue does not provide expected data on page 68.](#)
- [Printer Messages do not display on the PC on page 69.](#)

The Card Printer Driver does not detect the network-connected printer

Problem	Solution
<p>The Printer Properties > Status tab shows the printer is not available.</p>	<p>Make sure that you use the same type of data cable—USB or network—that was used when the printer was installed. You cannot switch the type of data cable after installation.</p> <p>Make sure that the current printer IP address is the same as the IP address on the Printer Properties > Ports tab. For more information about retrieving the printer’s IP address, refer to “Retrieve the Printer’s Network IP Address” on page 23.</p>
<p>Message 500 displays after you send a card to print.</p>	<p>If this happens often, consider switching from DHCP network addressing to static IP addressing. For more information about setting the Card Printer Driver network communication value, refer to the “Printer Manager” section of the card printer’s <i>Installation and Administrator’s Guide</i>.</p>
<p>The network is not operating properly.</p>	<p>Test the network using another device and fix or report network problems. To test the network, print to a different (paper) printer or verify the availability of network drives.</p>
<p>The printer is not connected to the network, or the PC is not connected to the network.</p>	<p>Make sure that both ends of the data cable are connected. Replace defective cables if needed.</p>

The Card Printer Driver does not detect the USB-connected printer

Problem	Solution
<p>The Printer Properties > Status tab shows the printer is available, but Message 500 displays after you send a card to print.</p>	<p>Make sure that you use the same type of data cable—USB or network—that was used when the printer was installed. You cannot switch the type of data cable after installation.</p> <p>Make sure that both ends of the data cable are connected. Replace a defective USB cable if needed.</p>

Driver status or Windows print queue does not provide expected data

Problem	Solution
The Card Printer Driver sample card or magnetic stripe test cards do not print.	Enable bidirectional support must be selected on the Printer Properties > Ports tab to allow printing from the Card Printer Driver.
The Ribbon Low light on the printer and the Card Printer Driver status do not match.	The percentage of ribbon remaining that causes the printer Ribbon Low light can be set using the Printer Manager FrontPanel printer setting. The driver displays the actual percentage of ribbon remaining and cannot be changed. As a result, the indicators may not be in agreement.
A print job disappears from the print queue but does not print.	The printer USB cable was disconnected after the application sent the job. Reconnect the cable and try the job again.
The Card Printer Driver Printer Status page shows a USB-connected printer as Ready , but a card sent to the printer does not print.	<p>The Windows print queue is offline. This can result if the printer is powered on before the computer. Do one of the following:</p> <ul style="list-style-type: none"> • Unplug the USB cable, and plug it back in. <p>or</p> <ul style="list-style-type: none"> • Place the print queue online: <ul style="list-style-type: none"> – Open the Devices and Printers control panel. – Right-click the printer icon and select See what’s printing to display Windows Print Manager. – Clear the check mark from Use Printer Offline in the Printer drop-down list. <p>We recommend that you turn on the PC and wait until it has started. Then, power on the printer.</p>

Printer Messages do not display on the PC

Problem	Solution
A USB-connected printer issues a message on the LCD but the message does not display on the PC.	<p>Windows has a 15-character limit for the computer name. If the computer name is longer than 15 characters, it treats the name as not valid and does not display the message. Do the following to change the computer name:</p> <ol style="list-style-type: none">1. Press the USER button on the printer to clear the message on the LCD.2. On the PC, open Control Panel/System and Security/System.3. Locate the computer name and click Change settings.4. Click Change on the System Properties window.5. Enter the new computer name on the Computer Name/Domain Changes dialog box and click OK. <p>Note: If your computer is part of a corporate domain, you may not be allowed to change the computer name. Contact your network administrator for more information.</p>

Card Appearance

Card appearance problems can be caused by many different factors. Click the link below that best describes the card appearance issue on the printed card.

- [Something did not print](#)
- [Printing includes unexpected data on page 71](#)
- [Print quality concerns on page 72](#)

Tools for Troubleshooting

The tools for troubleshooting a problem include the supplies and equipment you use to print cards:

- Blank cards to print, used at several stages of troubleshooting
- Ink ribbon and retransfer film
- Cleaning supplies, especially printer cleaning cards and a cleaning swab

Something did not print

Problem	Probable Cause	Solution
Nothing printed on the card.	The Disable Printing option in the Card Printer Driver is set to All, Front, or Back.	Open the Preferences > Layout > Advanced tab and change Disable Printing to Off .
	The ink ribbon or retransfer film is loaded incorrectly.	Remove the supply and install it correctly.
	The page size was not set to the correct size.	<ul style="list-style-type: none"> • If you use the Card printer Driver, use the page setup feature of your application to set the page size to ISO ID-1 Retransfer. The correct page size is available after you select the printer. Note: Some older applications, such as Datacard® ID Works® or IDCentre™, do not support the ISO ID-1 Retransfer paper size used by the CR805 retransfer printer. If your application does not, select the ISO ID-1 (85.60 x 53.98 mm) paper size in the Card Printer Driver. The driver adjusts the image so that it prints correctly on the larger image canvas used by the retransfer printer. Refer to the <i>XPS Card Printer Driver User's Guide</i> for more information. • If you use TruCredential software or another card production application, refer to your user documentation for information about how to specify the page size.

Printing includes unexpected data

Problem	Probable Cause	Solution
Text that was intended for the magnetic stripe printed on the card instead.	The magnetic stripe font was not applied to the text.	Refer to “Magnetic Stripe Fonts” in the <i>XPS Card Printer Driver User’s Guide</i> .
	The escape was typed incorrectly.	Refer to “Magnetic Stripe Escapes” in the <i>XPS Card Printer Driver User’s Guide</i> .
	The text to encode was longer than one line.	Reduce the font size to keep all text on one line.
Several blank cards are ejected before the full card prints.	The application uses the page size that is in effect when a card design document is created. Setting the page size after creating the document can cause errors.	Use the page setup feature of the application to set the page size before creating the document. Consider creating a template for cards that opens at the correct page size.

Print quality concerns

Problem	Probable Cause	Solution
One or more color or white streaks appear on the card.	Dust or debris on the printhead.	<ul style="list-style-type: none"> • Try printing another card as the dust may no longer be on the printhead. • Clean the printhead. Refer to “Clean the Printhead” on page 57. • If the printhead is damaged, contact your service provider.
Non-repeating color dots appear on multiple printed cards.	Dust or debris on the ink ribbon or retransfer film.	Advance the ink ribbon or retransfer film, or install new supplies.
Repeating color dots appear on multiple printed cards.	Dust or debris on the cam rollers located opposite the printhead.	Clean the printhead cam rollers with an adhesive cleaning card. Refer to “Clean the Printhead Cam Rollers” on page 56.
One color panel is not aligned correctly with other color panels.	The ink ribbon or retransfer film is slipping.	Contact your service provider to adjust the tension on the ink ribbon or retransfer film.
Card with darkly colored areas are not printing properly.	The card includes very dark areas.	<ul style="list-style-type: none"> • If possible, change the design to use smaller areas of dark color. • Use a different color ink ribbon. Contact your service provider for more information.
Color printing is darker than intended.	The black (K) panel of the ink ribbon is used to darken other colors, in addition to printing any black elements. The black ink is beneath the color (YMC) and UV (F) pigments when they are placed on the card.	Refer to “Elements of Card Design” in the printer’s <i>Installation and Administrator’s Guide</i> for suggestions and printing guidelines.

Problem	Probable Cause	Solution
Part of the printed image is discolored or blurred.	The cards have fingerprints or debris on them.	<ul style="list-style-type: none"> • Make sure that cards are clean. Handle cards carefully. Refer to “Card Quality Guidelines” in the printer’s <i>Installation and Administrator’s Guide</i>. • Use cards that meet the requirements for the printer. Refer to “Cards” in the printer’s <i>Installation and Administrator’s Guide</i>.
	The transport rollers are dirty.	Clean the printer and replace the cleaning sleeve. Refer to the “ Printer Cleaning Schedule ” on page 46 and “ Replace the Cleaning Sleeve ” on page 36.
	The printhead is dirty.	Clean the printhead. Refer to “ Clean the Printhead ” on page 57.
The printed card has small unprinted areas.	Unprinted cards have scratches.	Handle cards carefully. Refer to “Card Quality Guidelines” in the printer’s <i>Installation and Administrator’s Guide</i> .
	The transport rollers are dirty.	Clean the printer. Refer to the “ Printer Cleaning Schedule ” on page 46.
Wrinkles appear on the card.	The supplies are wrinkled.	<ul style="list-style-type: none"> • Check the ink ribbon and retransfer film. If either is wrinkled, advance the supply in the cartridge to an unwrinkled section. • Replace the supplies, if necessary.
	The printer firmware is not current.	Update the printer to the current firmware version. Firmware updates often contain fixes for common printing issues.

Problem	Probable Cause	Solution
The card has trapped dust or debris.	Particles from the retransfer process (flash) can accumulate inside the printer.	Clean the printer and printhead cam rollers. Refer to the “Printer Cleaning Schedule” on page 46 and “Clean the Printhead Cam Rollers” on page 56. Note: You may need to run multiple cleaning cycles to remove all particles from the printer.
	The card stock may have embedded particles.	Check your cards for defects. Replace the card stock, if necessary.
Retransfer material appears on the magnetic stripe, signature panel, or smart card chip.	Blocking regions are not set up correctly.	<ul style="list-style-type: none"> • Make sure that the blocking regions for card features are set up properly. Use the blocking regions in your card design software, or define custom regions. Refer to <i>“Non-Printing Areas”</i> in the printer’s <i>Installation and Administrator’s Guide</i> and <i>“Escapes”</i> in the <i>XPS Card Printer Driver User’s Guide</i>. • Note: The location and dimensions of the blocking regions can vary depending on the card stock you use. • Clean the printer. Refer to the “Printer Cleaning Schedule” on page 46.

Magnetic Stripe Troubleshooting

To begin troubleshooting a magnetic stripe problem, you can print a magnetic stripe test card from the Card Printer Driver. For the steps to follow, refer “Print a Driver Sample Card” in the *XPS Card Printer Driver User’s Guide*.

The printer uses the coercivity set using the LCD panel or in Printer Manager, and the data format set using Printer Manager.

Problem	Solution
Cards are not loaded correctly.	Load ISO cards with the magnetic stripe (back side) facing down and to the right. Refer to “Load Cards” on page 31.
Cards do not have a magnetic stripe.	Load magnetic stripe cards in the input hopper. If the cards have a magnetic stripe, check the quality of the cards. Change card stock, if needed.
The card has dirt or damage on the magnetic stripe.	Encode and send a new card to print. If an error message indicates a magnetic stripe problem, run a cleaning card to clean the magnetic stripe head. Refer to the “Printer Cleaning Schedule” on page 46.
The magnetic stripe on the card is low-coercivity material and the High Coercivity setting is selected.	To use the cards you have, select low-coercivity encoding. Refer to “MagStripeGeneral” in the printer’s <i>Installation and Administrator’s Guide</i> for more information. To encode with high coercivity, obtain cards manufactured for high-coercivity encoding.
The magnetic stripe on the card is high-coercivity material and the Low Coercivity setting is selected.	To use the cards you have, select high-coercivity encoding. Refer to “MagStripeGeneral” in the printer’s <i>Installation and Administrator’s Guide</i> for more information. To encode with low coercivity, obtain cards manufactured for low-coercivity encoding.
The data for this job includes characters not allowed by the magnetic stripe format selected for the track.	Cancel the current print job. Make sure that you know which characters are allowed on the track. Change the data to be encoded, and resend the print job. Refer to “Magnetic Stripe Design” in the printer’s <i>Installation and Administrator’s Guide</i> for more information.

Problem	Solution
<p>The magnetic stripe data was sent in an encoding format not supported by the track.</p>	<p>Review the encoding format setting for the tracks in Printer Manager. Refer to “MagStripeGeneral” in the printer’s <i>Installation and Administrator’s Guide</i> for more information. Make sure that the application is using the selected encoding format for the track.</p> <p>If the application and track are set to the same format, and the error message displays repeatedly, contact the application provider for assistance.</p>
<p>The application sent track data for a track not supported by the magnetic stripe module.</p>	<p>Verify the type of magnetic stripe option in the printer.</p> <p>If the printer label indicates a 3-track ISO module, you can send data for tracks 1, 2, and 3.</p> <p>If the printer label indicates a single-track JIS module, you can send data for track 1.</p> <p>The magnetic stripe option and cards must be capable of accepting and encoding each track of data sent by the card production software.</p>

Laminator Troubleshooting

If your system includes the optional laminator, also check for the following.

Problem	Probable Cause	Solution
Cards are bowed too much following lamination.	The Debow card option is not selected.	Select the Debow card option in the Card Printer Driver. Refer to the <i>XPS Card Printer Driver User's Guide</i> .
	Debow time is not set correctly.	Change the card debow time. Refer to the Printer Manager "Laminator" section of the printer's <i>Installation and Administrator's Guide</i> .
	The temperature is too high for the card stock used.	Lower the laminator temperature for the overlay material. Refer to the Printer Manager "Laminate Type" section of the printer's <i>Installation and Administrator's Guide</i> .
	The card stock doesn't work with the overlay.	Switch to a different card stock.
The patch comes off when the card is flexed.	The temperature is too low for the overlay material.	Increase the laminator temperature for the overlay material. Refer to the Printer Manager "Laminate Type" section of the printer's <i>Installation and Administrator's Guide</i> .
	A patch is stuck to the heated roller.	Clean the laminator. Refer to " Clean the Laminator " on page A-12 . If the problem continues to occur, contact your service provider.
There are scratches or particles under the patch.	The inside of the printer is dirty.	Clean the printer. Refer to the " Printer Cleaning Schedule " on page 46 .
	The supplies have debris on them.	Store and handle supplies carefully. Keep supplies in the original packaging until you are ready to use them.
There are repeating marks on the patch.	The heated roller is dirty.	Clean the laminator. Refer to " Clean the Laminator " on page A-12 . If the problem continues to occur, contact your service provider.

Problem	Probable Cause	Solution
The patch doesn't adhere to the trailing edge of the card.	The overlay is wound incorrectly on the take-up spool.	Process another card to allow the overlay material to reset itself. If it doesn't, remove the cartridge and turn the take-up spool clockwise several turns.
The patch is not centered between the long edges of the card.	The overlay is not loaded correctly in the cartridge.	Load the overlay material correctly. Refer to "Load Laminator Overlay Material" on page A-8 .
	The laminator cartridge is not fully seated in the laminator.	Make sure that the cartridge is seated in the laminator properly.
	The overlay material is wound unevenly on the supply roll.	Process several cards to allow the overlay material to center itself. Align the edges of the overlay on the take-up spool.
	The laminator cartridge is damaged.	Replace the laminator cartridge. Refer to the printer's <i>Installation and Administrator's Guide</i> for information about ordering replacement parts.
The patch has wavy lines along the length of the card.	The temperature for applying the overlay is set too high.	Decrease the laminator temperature setting. Refer to the Printer Manager "Laminate Type" section of the printer's <i>Installation and Administrator's Guide</i> .
	The heated roller is damaged.	Power down the system. Contact your service provider for assistance.
	The card has features, such as a smart card chip, that interfere with application of the overlay.	Use the correct patch material for your card type. Refer to "Laminator Overlay Materials" on page A-6 for a description of overlay types.
The patch shows opaque areas at the leading edge of the card.	The temperature for applying the overlay is too high.	Decrease the laminator temperature setting. Refer to the Printer Manager "Laminate Type" section of the printer's <i>Installation and Administrator's Guide</i> . If the problem continues to occur, contact your service provider for assistance.

Problem	Probable Cause	Solution
The patch extends beyond one of the short edges of the card.	There is slack in the overlay material.	Process another card to allow the overlay material to reset itself.
	The overlay material is wound incorrectly on the take-up spool.	Remove the laminator cartridge and turn the take-up spool clockwise several turns.
	The card or overlay registration settings are not correct.	Contact your service provider for assistance.
The patch is missing from the finished card.	The supply spool is not positioned correctly in the cartridge.	Make sure that the overlay is loaded correctly. Refer to “Load Laminator Overlay Material” on page A-8 .
	The overlay was moved on the spool and the patch was used previously.	Advance the overlay past the used area. If the problem continues to occur, contact your service provider.
	The Card Printer Driver Lamine card setting was set to Do not apply.	Change the Lamine card setting to apply the overlay. Refer to the <i>XPS Card Printer Driver User’s Guide</i> for information about specifying lamination settings.

Advanced Troubleshooting Tools

Printer Manager provides access to card design settings and additional troubleshooting tools. Printer Manager also allows you to perform advanced troubleshooting with the guidance of your service provider. Refer to the “Printer Manager” section in the printer’s *Installation and Administrator’s Guide* for more information.

Printer Card Jams

A card jam occurs when the card does not reach the proper position for the next action, such as printing or ejecting the card. The error condition that displays on the LCD helps you identify the location of the card jam.



If your system includes the optional laminator, refer to “Clear a Laminator Card Jam” on page A-11.

Clear a Card Jam in the K1 Horizontal Transport

If message 234: “K1 transport card jam” displays, you usually can resolve the error by pressing the USER button to move the card into the reject tray. If the error persists, do the following to remove the card from the printer.

Single-Hopper Printer

1. Unlock the printer, if necessary, and open the printer access door.
2. Remove the retransfer film cartridge.

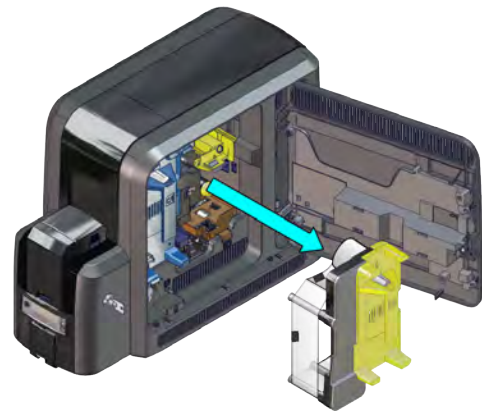

3. Turn the K1 manual advance knob counterclockwise to move the jammed card into the output hopper.
4. Remove the card through the output hopper.
5. Replace the retransfer film cartridge and close the printer access door.
6. Lock the printer, if necessary.
7. Press the USER button on the printer to clear the message.

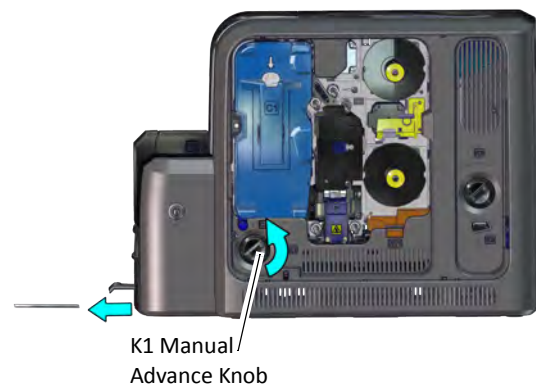

Multi-Hopper Printer

1. Unlock the printer and open the printer access door.
2. Remove the ink ribbon and retransfer film cartridges.
3. Locate the card in the printer. Turn the K1 manual advance knob if necessary to gain access to the card.
4. Reach into the printer and remove the card.
5. Replace the ink ribbon and retransfer film cartridges.
6. Close the printer access door and lock the printer.
7. Press the USER button on the printer to clear the message.

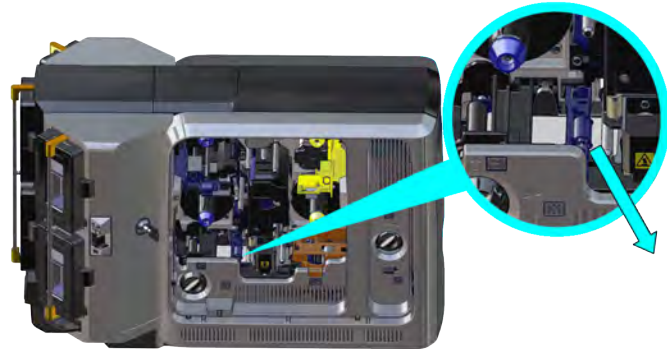

HINTS & TIPS

Check the ink ribbon and retransfer film to make sure that they are not broken. Refer to [“Repair a Broken Ink Ribbon or Retransfer Film”](#) on [page 83](#).

Clear a Card Jam in the K2 Vertical Transport

The vertical transport houses the magnetic stripe module and smart card reader. If message 235: “K2 transport card jam” displays, you usually can resolve the error by pressing the USER button to move the card into the reject tray. If the error persists, do the following to remove the card from the printer.

1. Unlock the printer, if necessary, and open the printer access door.
2. Press the K3 rear access door release to open the rear access door.
3. Turn the K2 manual advance knob counterclockwise to move the jammed card inside the vertical transport until it is accessible through the rear access door.



4. Remove the card through the rear access door.
5. Close the rear access door.
6. Close the printer access door and lock the printer, if necessary.
7. Press the USER button on the printer to clear the message.

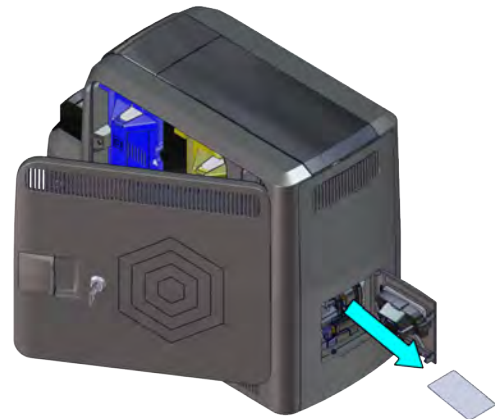

Clear a Card Jam in the Flipper Module

Do the following if message 236: "Flipper module rotate error" displays.

1. Unlock the printer, if necessary, and open the printer access door.
2. Press the K3 rear access door release to open the rear access door.



3. Reach into the flipper module and rotate it until you can access the card.
4. Remove the card through the rear access door.
5. Close the rear access door.
6. Close the printer access door and lock the printer, if necessary.
7. Press the USER button on the printer to clear the message.



Repair a Broken Ink Ribbon or Retransfer Film

If the ink ribbon or retransfer film breaks, one of the following messages displays on the printer LCD:

- **240, C1 supply error** There is a problem with the ink ribbon.
- **175, C2 supply error** There is a problem with the retransfer film.

1. Unlock the printer, if necessary, and open the printer access door.
2. Remove the cartridge with the damaged supply from the printer.

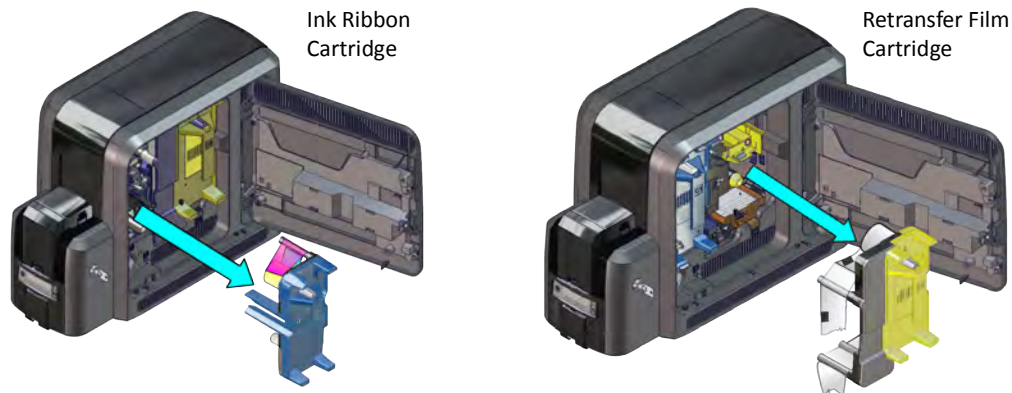

3. Trim the ends of the broken ribbon or film evenly.



Do not remove the used ink ribbon or retransfer film from the take-up spool. Removing, and then reinstalling, the supply on the take-up spool may cause printing issues.

4. Align the ends of the broken media evenly and apply adhesive tape to secure them.

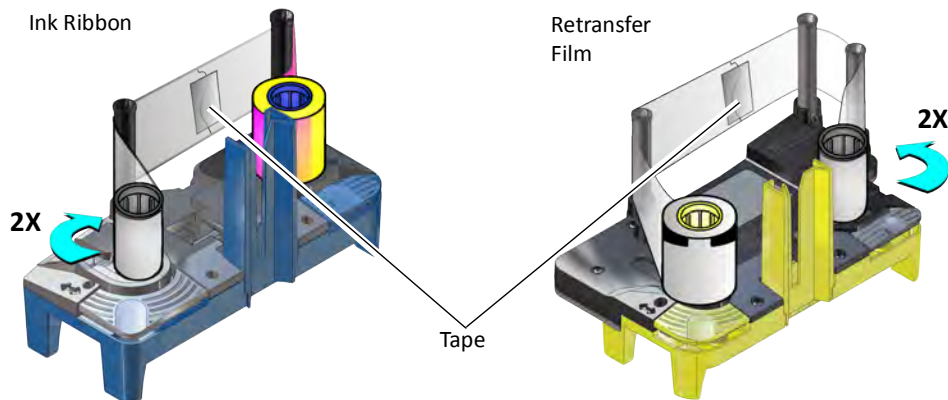

5. Turn the take-up spool until the mended portion is wound onto the spool two or three turns.

Make sure that the ink ribbon or retransfer film is routed as shown on the cartridge and that there are no wrinkles in the supply.

6. Remove any slack in the ink ribbon or retransfer film.
7. Reinstall the cartridge into the printer until it clicks into position.
8. Close the printer access door and lock the printer, if necessary.

Messages and Conditions

When the system cannot process the card sent, it issues a condition. Conditions display on the LCD panel on the front panel of the printer. When you use the Card Printer Driver, the printer driver also displays the condition as a message on the PC that sent the print job. Refer to the following for more information:

- [Messages on the Printer LCD](#)
- [Messages from the Card Printer Driver on the PC on page 88](#)
- [Messages from Printer Manager on page 89](#)
- [Other Messages on page 89](#)

Messages on the Printer LCD

All messages are associated with a print job. The printer issues messages that focus on recovering from problems.

- The printer displays a message number and a short description for each message.
- If asked by Technical Support, press the down arrow to display a service code that further isolates the cause of the error.
- If more than one message was issued, the next message displays after you correct the problem and press the USER button.
- The lights on the front panel flash while messages display on the LCD panel.

Printer Messages

No.	LCD Message	User Light	Supply Light	Card Light
–	Close and lock doors	Color Cycle	Off	Off
100	Request not supported	Amber Flash	Off	Off
103	Printer problem	Amber Flash	Off	Off
104	Critical problem	Amber Flash	Amber Flash	Amber Flash
105	Magstripe data error	Amber Flash	Off	Off
106	Magstripe data not found	Off	Off	Amber Flash

No.	LCD Message	User Light	Supply Light	Card Light
107	Magstripe read data error	Off	Off	Amber Flash
108	Magstripe read no data	Off	Off	Amber Flash
111	Card not picked	Off	Off	Amber Flash
112	Card hopper empty	Off	Off	Amber Flash
113	Close cover to continue	Amber Flash	Off	Off
114	Cover opened during job	Amber Flash	Off	Off
116	Magstripe not available	Amber Flash	Off	Off
117	Reader not available	Amber Flash	Off	Off
120	User paused the printer	Amber Flash	Off	Off
122	Magstripe format problem	Amber Flash	Off	Off
149	Option not installed	Amber Flash	Off	Off
150	Print while unlocked	Amber Flash	Off	Off
151	Failed to lock	Amber Flash	Off	Off
152	Insert new card side 2 up	Amber Flash	Off	Off
153	Insert same card side 2 up	Amber Flash	Off	Off
166	C2 supply out or missing	Off	Amber Flash	Off
167	C2 supply not identified	Off	Amber Flash	Off
168	C2 supply not supported	Off	Amber Flash	Off
170	Insert new card side 1 up	Amber Flash	Off	Off
171	Insert same card side 1 up	Amber Flash	Off	Off
172	Insert cleaning card	Off	Off	Amber Flash
173	Improper shutdown	Amber Flash	Off	Off
175	C2 supply error	Off	Amber Flash	Off
176	C2 supply type error	Off	Amber Flash	Off

No.	LCD Message	User Light	Supply Light	Card Light
228	C1 printhead error	Amber Flash	Off	Off
229	C2 heat sensor error	Amber Flash	Off	Off
230	C2 heater error	Amber Flash	Off	Off
231	C2 heated roller motion error	Amber Flash	Off	Off
232	Retransfer debow error	Amber Flash	Off	Off
233	Smart card contact fail	Amber Flash	Off	Off
234	K1 transport card jam	Off	Off	Amber Flash
235	K2 transport card jam	Off	Off	Amber Flash
236	Flipper module rotate error	Amber Flash	Off	Off
237	C1 supply out or missing	Off	Amber Flash	Off
238	C1 supply not identified	Off	Amber Flash	Off
239	C1 supply not supported	Off	Amber Flash	Off
240	C1 supply error	Off	Amber Flash	Off
241	C1 supply type error	Off	Amber Flash	Off
242	RT1 reject tray full	Off	Off	Amber Flash
243	Card lost	Off	Off	Amber Flash
245	Configuration error	Green Flash	Off	Off
275	Multi-hopper error	Green Flash	Green Flash	Green Flash
276	Multi-hopper card jam	Off	Off	Green Flash
277	Multi-hopper pick error	Off	Off	Green Flash
278	Insert cleaning card in H2	Off	Off	Amber Flash

Laminator Messages

No.	LCD Message	User Light	Supply Light	Card Light	Laminator Light
177	Laminator not available	Green Flash	Off	Off	
196	Laminator error critical	Green Flash	Green Flash	Green Flash	Red Flash
197	Laminator entry card problem	Off	Off	Green Flash	Red Flash
198	L1 area card problem	Off	Off	Green Flash	Red Flash
199	L2 area card problem	Off	Off	Green Flash	Red Flash
200	Laminator exit card problem	Off	Off	Green Flash	Red Flash
201	L1 supply problem	Off	Green Flash	Off	Red Flash
202	L1 supply out or missing	Off	Green Flash	Off	Red Flash
203	L1 supply type problem	Off	Green Flash	Off	Red Flash
204	L1 supply not supported	Off	Green Flash	Off	Red Flash
205	L1 supply not identified	Off	Green Flash	Off	Red Flash
206	L2 supply problem	Off	Green Flash	Off	Red Flash
207	L2 supply out or missing	Off	Green Flash	Off	Red Flash
208	L2 supply type problem	Off	Green Flash	Off	Red Flash
209	L2 supply not supported	Off	Green Flash	Off	Red Flash
210	L2 supply not identified	Off	Green Flash	Off	Red Flash
211	L1 heater problem	Green Flash	Off	Off	Red Flash
212	L2 heater problem	Green Flash	Off	Off	Red Flash
213	L1 heater sensor problem	Green Flash	Off	Off	Red Flash
214	L2 heater sensor problem	Green Flash	Off	Off	Red Flash
215	L1 heater roller problem	Green Flash	Off	Off	Red Flash

No.	LCD Message	User Light	Supply Light	Card Light	Laminator Light
216	L2 heater roller problem	Green Flash	Off	Off	Red Flash
217	Debow problem	Green Flash	Off	Off	Red Flash
218	Impresser problem	Green Flash	Off	Off	Red Flash
219	Impresser sensor problem	Green Flash	Off	Off	Red Flash
220	Impresser heater problem	Green Flash	Off	Off	Red Flash
221	Bar code scanner problem	Green Flash	Off	Off	Red Flash
222	Firmware version mismatch	Green Flash	Green Flash	Green Flash	Red Flash
223	Laminator system mismatch	Green Flash	Green Flash	Green Flash	Red Flash

Messages from the Card Printer Driver on the PC

- The Card Printer Driver displays the same messages as those on the printer LCD panel. The messages that display on the PC provide additional information about the condition that caused the message and contain recovery instructions. Click the appropriate button to clear the message.
- Messages display on the PC that sent the card print job.
- If you cancel a job at the printer, the message is removed from the PC. Any additional messages for the canceled job (for example, for a broken ribbon) do not display on the PC.
- Messages can display in the background, behind the application sending the card. On some operating systems, the message displays in the status bar. Click the blinking Explorer (folder) icon in the status bar to open the message.
- If more than one message was issued, the next message displays after you close the current message.
- If there is more than one card printer installed on the PC, messages display one at a time. The title bar of each message shows the printer name.
- The Card Printer Driver also can issue messages. Refer to [“Driver-Only Messages”](#) on [page 110](#) and [“Driver SDK Messages”](#) on [page 112](#) for a list of these messages.

Messages from Printer Manager

Printer Manager issues messages that display in the browser window. Follow the instructions in the message to continue working with the printer. Refer to “Printer Manager” in your printer’s *Installation and Administrator’s Guide*.

Other Messages

- The card production application you use also may issue messages.
- Other printers can cause messages if more than one model of card printer is installed.

Respond to Messages

Messages display on the printer front panel LCD and in a message on the PC that issued the card print job when you use the Card Printer Driver. The messages help you to identify various operational conditions and errors of card production on the system. You can respond to messages using the printer front panel buttons or by clicking the appropriate response in the message displayed on the PC.



The messages that display are determined by the printer model and the options installed in the printer. The messages described in the following sections may not display on all printers.

Important! Always discard damaged, rejected, or partially printed cards according to your organization’s established procedures.

The following messages display on the printer LCD panel. Use the recovery instructions to respond to the message.

- [Printer Messages on page 90](#)
- [Laminator Messages on page 103](#)

Printer Messages

The following messages indicate a condition in the printer.

Close and lock doors

A secure door is physically unlocked on the system.

1. Gently try to open all secure doors on the system.
2. Close any open door and lock the printer using the key.

100: Request not supported

The printer does not support the personalization being requested for the card. The card will be canceled.

Change the card data to match the printer's options and settings, or print to a printer that is configured to support the personalization being requested.

Press the USER button on the printer, or click **OK** on the PC, to clear the message.

Send the card again.

103: Printer problem

The printer had an error. The card will be canceled.

1. Press the printer POWER button to power off the printer.
2. Press the POWER button again to power on the printer.

Click **OK** on the PC to clear the message.

104: Critical problem

The printer had a serious error. The card will be canceled.

1. Press the printer POWER button to power off the printer.
2. Request service.

The system must remain powered off.

Click **OK** on the PC to clear the message.

105: Magstripe data error

The printer failed to verify that the correct magnetic stripe data was written on the card.

1. Make sure that you are using magnetic stripe cards that match the printer settings.
2. Make sure that the cards are placed in the printer correctly.

Press the **USER** button on the printer to clear the message and send the card to print again. On the PC, click **Retry**, or click **Cancel** to cancel the card.

HINTS & TIPS

- The card might have been loaded into the input hopper the wrong way. A diagram inside the input hopper shows the correct orientation.
- The card might not have a magnetic stripe.

106: Magstripe data not found

The printer did not find magnetic stripe data on card.

1. Make sure that you are using magnetic stripe cards that match the printer settings.
2. Make sure that the cards are placed in the printer correctly.

Press the **USER** button on the printer to clear the message and send the card to print again. On the PC, click **Retry**, or click **Cancel** to cancel the card.

HINTS & TIPS

- The card might not match printer settings or the data sent.
- Ask the system administrator to verify that the card, the data, and the printer settings match.

107: Magstripe read data error

The printer failed to read the magnetic stripe data from the card. The card will be canceled.

1. Make sure that you are using magnetic stripe cards that match the printer settings.
2. Make sure that the cards are placed in the printer correctly.

Press the **USER** button on the printer to clear the message. On the PC, click **OK** to clear the message. Send the card job to the printer again.

HINTS & TIPS

- The data might use a different format than the current printer setting.
- Ask the system administrator to verify that the card, data, and printer settings match.

108: Magstripe read no data

The printer did not find any magnetic stripe data on the card. The card will be canceled.

1. Make sure that you are using magnetic stripe cards that match the printer settings.
2. Make sure that the cards are placed in the printer correctly.

Press the **USER** button on the printer to clear the message. On the PC, click **OK** to clear the message.

HINTS & TIPS

- The card might have been turned the wrong way. A diagram inside the input hopper shows the correct orientation.
- The card might not have a magnetic stripe.

111: Card not picked

The printer did not pick a card. To complete the current card:

For printers with an input hopper, open the input hopper, add or reposition cards, and close the hopper.

For printers with single card feed, push the card in until the printer picks it.

Press the **USER** button on the printer to clear the message. On the PC, click **Retry**, or click **Cancel** to cancel the card.

112: Card hopper empty

The printer did not detect cards in the input hopper.

Add cards to the input hopper.

Press the **USER** button on the printer to clear the message. On the PC, click **Retry**, or click **Cancel** to cancel the card.

113: Close cover to continue

The cover is open or the print ribbon cartridge is missing.

Confirm that the print ribbon cartridge is installed and then close the cover.

Press the USER button on the printer to clear the message. On the PC, click **Retry**, or click **Cancel** to cancel the card.

HINTS & TIPS

- Make sure that the ink ribbon and retransfer cartridges are installed properly.
- All access doors must be closed to process cards. Unlock, open, and close all printer doors to make sure they are closed completely.
- Lock the system.

114: Cover opened during job

The printer cover was opened while printing.

Close the printer cover completely.

Press the USER button on the printer to clear the message. On the PC, click **Retry**, or click **Cancel** to cancel the card.

HINTS & TIPS

- Make sure that the ink ribbon and retransfer cartridges are installed properly.
- All access doors must be closed to process cards. Unlock, open, and close all printer doors to make sure they are closed completely.
- Lock the system.

116: Magstripe not available

The printer does not have a magnetic stripe option. The card will be canceled.

Remove magnetic stripe data from the card or use a printer that has a magnetic stripe option installed.

Press the **USER** button on the printer to clear the message. On the PC, click **OK** to clear the message.

HINTS & TIPS

- Look at the printer configuration label inside the printer component. If the label includes an "M," the system has a magnetic stripe option that is not working. Request service.
- To process the card without magnetic stripe processing, remove the magnetic stripe data from the card design and send it again.

117: Reader not available

The printer does not support the personalization being requested for the card. The card will be canceled.

Change the card data to match the printer's options and settings or print to a printer that is configured to support the personalization being requested.

Press the **USER** button on the printer, or click **OK** on the PC, to clear the message.

HINTS & TIPS

The printer component does not have a reader option. Remove the reader request from the card and send it again.

120: User paused the printer

The printer was paused while printing.

To complete the current card press the printer's **USER** button.

On the PC, click **OK** to clear the message and complete the current card, or click **Cancel** to cancel the card.

HINTS & TIPS

- If the user pressed the button for several seconds, the card has been canceled.
- If this message occurs often, ask your system administrator to set the button sensitivity to a lower value.

122: Magstripe format problem

The magnetic stripe data sent does not match the format set in the printer. The card will be canceled.

Press the **USER** button on the printer, or click **OK** on the PC, to clear the message.

149: Option not installed

The printer does not support the personalization being requested for the card. The card will be canceled.

Change the card data to match the printer's options and settings, or print to a printer that is configured to support the personalization being requested.

Press the **USER** button on the printer, or click **OK** on the PC, to clear the message.

150: Print while unlocked

The printer is unlocked. The card will be canceled.

Make sure that all access doors are closed securely and locked.

Click **OK** on the PC to clear the message.

151: Failed to lock

An attempt to lock the printer failed. The card will be canceled.

1. Make sure that all access doors are closed securely.
2. Try locking the printer again.

Click **OK** on the PC to clear the message.

HINTS & TIPS

Make sure that the reject tray is installed properly before locking the printer.

152: Insert new card side 2 up

1. Turn a new card over end to end so side 2 is facing up.
2. Insert the card in the printer.
3. If the card is not immediately picked, press the printer's **USER** button or click **OK**.

Click **Cancel** on the PC if you want to cancel the card.

153: Insert same card side 2 up

1. Take the card from the printer and turn it over end to end so side 2 is facing up.
2. Insert the card in the printer.
3. If the card is not immediately picked, press the printer's USER button or click **OK**.

Click **Cancel** on the PC if you want to cancel the card.

166: C2 supply out or missing

The C2 retransfer film is missing or out of material.

1. Open the printer access door and remove the C2 retransfer film cartridge.
2. Replace the retransfer film.
3. Replace the C2 retransfer film cartridge.
4. Close the printer access door.

Press the USER button on the printer to clear the message. On the PC, click **OK**, or click **Cancel** to cancel the card.

HINTS & TIPS

Refer to [“Replace the Retransfer Film”](#) on [page 38](#) for more information.

167: C2 supply not identified

The printer cannot use the C2 retransfer film installed. The card will be canceled.

Use a supply designed for this printer.

Press the USER button on the printer to clear the message. On the PC, click **Cancel**.

168: C2 supply not supported

The printer model cannot use the C2 retransfer film installed. The card will be canceled.

Use a supply designed for this printer model.

Press the USER button on the printer to clear the message. On the PC, click **Cancel**.

170: Insert new card side 1 up

1. Insert a new card in the printer with side 1 facing up.
2. If the card is not immediately picked, press the printer's USER button or click **OK**.

Click **Cancel** on the PC if you want to cancel the card.

171: Insert same card side 1 up

1. Take the card from the printer and turn it over end to end so side 1 is facing up.
2. Insert the card in the printer.
3. If the card is not immediately picked, press the printer's User button or click **OK**.

Click **Cancel** on the PC if you want to cancel the card.

172: Insert cleaning card

1. Insert cleaning card.
2. If the card is not immediately picked, press the printer's USER button or click **OK**.

Click **Cancel** on the PC to cancel the cleaning card.

173: Improper shutdown

Always use the POWER button to power off the printer.

Press and hold the USER button to set the printer to **Ready**.

Click **OK** on the PC to clear the message.

HINTS & TIPS

The system was shut down incorrectly or lost power.

175: C2 supply error

The C2 retransfer film has encountered an error.

1. Open the printer access door and remove the C2 retransfer film cartridge.
2. Reposition, repair, or replace the supply and advance the repaired area one full turn.
3. Replace the C2 retransfer film cartridge.
4. Close the printer access door.

Press the USER button on the printer to clear the message. On the PC, click **Retry**, or click **Cancel** to cancel the card.

HINTS & TIPS

Refer to ["Replace the Retransfer Film"](#) on page 38 or ["Repair a Broken Ink Ribbon or Retransfer Film"](#) on page 83 for more information.

176: C2 supply type error

The C2 retransfer film does not support an action requested by this print job.

Use a supply designed for this printer model.

Press the **USER** button on the printer to clear the message. On the PC, click **Retry**, or click **Cancel** to cancel the card.

228: C1 printhead error

The printer has encountered a critical error. The card will be canceled.

1. Press the printer **POWER** button to power off the system.
2. Request service. The system must remain powered off.

Click **OK** on the PC to clear the message.

229: C2 heat sensor error

The C2 retransfer heat sensor has encountered a critical error. The card will be canceled.

1. Press the printer **POWER** button to power off the system.
2. Request service. The system must remain powered off.

Click **OK** on the PC to clear the message.

230: C2 heater error

The C2 retransfer heater has encountered a critical error. The card will be canceled.

1. Press the printer **POWER** button to power off the system.
2. Request service. The system must remain powered off.

Click **OK** on the PC to clear the message.

231: C2 heated roller motion error

The C2 retransfer heated roller has encountered a critical error. The card will be canceled.

1. Press the printer **POWER** button to power off the system.
2. Request service. The system must remain powered off.

Click **OK** on the PC to clear the message.

232: Retransfer debow error

The printer has encountered an error in the retransfer debow area. The card will be canceled.

1. Press the USER button to move the card into the reject tray and clear the error.
2. If the error occurs again, open the printer access door and look for a card in the debow area.
3. Turn the K1 manual advance knob to move the card out of the printer.
4. If the problem continues to occur, request service.

On the PC, click **Cancel**.

233: Smart card contact fail

There is a critical error with the smart card contact. The card will be canceled.

1. Press the USER button to move the card into the reject tray and clear the error.
2. Send the card job to the printer again.

Click **OK** on the PC to clear the message.

234: K1 transport card jam

The card did not reach the required position on the K1 horizontal transport. The card will be canceled.

1. Press the USER button to move the card into the reject tray and clear the error.
2. If the error occurs again, open the printer access door and remove the C2 retransfer film cartridge.
3. Turn the K1 manual advance knob counterclockwise to move the card to the output hopper.
4. Remove the card from the output hopper.
5. Replace the retransfer film cartridge.
6. Close the printer access door.

On the PC, click **Retry**, or click **Cancel** to cancel the card.

235: K2 transport card jam

The card did not reach the required position on the K2 vertical transport. The card will be canceled.

1. Press the **USER** button to move the card into the reject tray and clear the error.
2. If the error occurs again, open the printer access door.
3. Press the K3 rear access door release to open the rear access door.
4. Turn the K2 manual advance knob counterclockwise to move the card until it is accessible.
5. Remove the card through the rear access door.
6. Close the printer access doors.

On the PC, click **Retry**, or click **Cancel** to cancel the card.

236: Flipper module rotate error

The flipper did not reach the required position.

1. Open the printer access door.
2. Press the K3 rear access door release to open the rear access door.
3. Reach in and rotate the flipper module until the card is accessible.
4. Remove the card through the rear access door.
5. Close the rear access door and then close the printer access door.

Press the **USER** button to clear the message. On the PC, click **Retry**, or click **Cancel** to cancel the card.

237: C1 supply out or missing

The C1 ink ribbon is missing or out of material.

1. Open the printer access door and remove the C1 ink ribbon cartridge.
2. Replace the ink ribbon.
3. Replace the ink ribbon cartridge.
4. Close the printer access door.

Press the **USER** button on the printer to clear the message. On the PC, click **OK**, or click **Cancel** to cancel the card.

HINTS & TIPS

Refer to [“Replace the Ink Ribbon”](#) on [page 34](#) for more information.

238: C1 supply not identified

The printer cannot use the C1 ink ribbon installed.

Use a supply designed for this printer.

Press the USER button on the printer to clear the message. On the PC, click **Cancel**.

239: C1 supply not supported

The printer model cannot use the C1 ink ribbon installed.

Use a supply designed for this printer model.

Press the USER button on the printer to clear the message. On the PC, click **Cancel**.

240: C1 supply error

The C1 ink ribbon has encountered an error.

1. Open the printer access door and remove the C1 ink ribbon cartridge.
2. Reposition, repair, or replace the ink ribbon and advance the repaired area one full turn.
3. Replace the ink ribbon cartridge.
4. Close the printer access door.

Press the USER button on the printer to clear the message. On the PC, click **Retry**, or click **Cancel** to cancel the card.

HINTS & TIPS

Refer to [“Replace the Ink Ribbon”](#) on page 34 or [“Repair a Broken Ink Ribbon or Retransfer Film”](#) on page 83 for more information.

241: C1 supply type error

The C1 ink ribbon does not support an action requested by this print job.

Use a supply designed for this printer model.

Press the USER button on the printer to clear the message. On the PC, click **Retry**, or click **Cancel** to cancel the card.

242: RT1 reject tray full

The reject tray is full.

1. Open the printer access door.
2. Remove the retransfer film cartridge.
3. Remove the rejected cards.
4. Replace the retransfer film cartridge.
5. Close the printer access door.

Press the **USER** button on the printer to clear the message. On the PC, click **OK**, or click **Cancel** to cancel the card.

243: Card lost

A card that is expected to be in the printer is no longer present. The card will be canceled and added to the Lost Cards count. Send the job to print again.

Press the **USER** button on the printer to clear the message. On the PC, click **OK**, or click **Cancel** to cancel the card.

245: Configuration error

The configuration is not compatible with the printer model. The printer cannot print cards until the configuration issue is corrected. Contact your service provider for assistance.

Click **OK** on the PC to clear the message.

275: Multi-hopper error

The multi-hopper has encountered a critical error. The card will be canceled.

1. Press the printer **POWER** button to power off the printer.
2. Press the **POWER** button again to power on the printer.

If the error occurs again, request service.

On the PC, click **OK** to clear the message.

276: Multi-hopper card jam

The multi-hopper did not move a card into the printer.

Press the **USER** button to clear the error. If a card was jammed, it is moved to the reject tray.

On the PC, click **Retry**, or click **Cancel** to cancel the card.

277: Multi-hopper pick error

The multi-hopper did not pick a card from the input hopper cartridge.

1. Unlock the multi-hopper.
2. Remove each cartridge and make sure that cards are loaded properly.
3. Make sure that the cartridges are installed correctly.
4. Check the exception slide.
5. Lock the multi-hopper.

Press the **USER** button to clear the error.

On the PC, click **Retry**, or click **Cancel** to cancel the card.

278: Insert cleaning card in H2

1. Unlock the multi-hopper.
2. Remove unused cards and insert the cleaning card in hopper 2.
3. Close and lock the multi-hopper.
4. Press the printer's **USER** button to pick the card.

On the PC, click **OK**, or click **Cancel** to cancel the card.

Laminator Messages

The following messages display on the printer LCD panel when you are using a laminating system. They also display in a message on the PC that issued the card print job when you use the Card Printer Driver.

177: Laminator not available

The printer and laminator cannot communicate. The card will be canceled.

1. Make sure the data cable from the laminator to the printer is securely plugged in.
2. Press the printer **POWER** button to power off the system.
3. Press the **POWER** button again to power on the system.

On the PC, click **Retry**, or click **Cancel** to cancel the card.

196: Laminator error critical

The laminator has encountered a critical error. The card will be canceled.

1. Press the printer **POWER** button to power off the system.
2. Request service. The system must remain powered off.

On the PC, click **OK** to clear the message.

197: Laminator entry card problem

The card is not where it should be in the laminator.

1. Open the laminator.
2. Turn the knob to remove the card.
3. Close the laminator.

On the PC, click **Retry**, or click **Cancel** to cancel the card.

198: L1 area card problem

The card is not where it should be in the laminator.

1. Open the laminator and remove the L1 supply cartridge.
2. Turn the knob to remove the card.
3. Replace the supply cartridge and close the laminator.

On the PC, click **Retry**, or click **Cancel** to cancel the card.

199: L2 area card problem

The card is not where it should be in the laminator.

1. Open the laminator and remove the L2 supply cartridge.
2. Turn the knob to remove the card.
3. Replace the supply cartridge and close the laminator.

On the PC, click **Retry**, or click **Cancel** to cancel the card.

200: Laminator exit card problem

The card is not where it should be in the laminator.

1. Open the laminator.
2. Turn the knob to remove the card.
3. Close the laminator.

On the PC, click **Retry**, or click **Cancel** to cancel the card.

201: L1 supply problem

The L1 supply is not moving properly. To try another card:

1. Open the laminator and remove the L1 cartridge.
2. Reposition, repair, or replace the supply and advance the repaired area one full turn.
3. Replace the cartridge and close the laminator.

On the PC, click **Retry**, or click **Cancel** to cancel the card.

202: L1 supply out or missing

The laminator does not have usable supplies.

1. Open the laminator.
2. Replace the supply.
3. Close the laminator.

On the PC, click **OK**, or click **Cancel** to cancel the card.

203: L1 supply type problem

The laminator cannot use the supply installed.

Use supplies designed for this laminator.

On the PC, click **Retry**, or click **Cancel** to cancel the card.

204: L1 supply not supported

The laminator cannot use the supply installed.

Use supplies designed for this laminator.

On the PC, click **Retry**, or click **Cancel** to cancel the card.

205: L1 supply not identified

The laminator cannot use the supply installed.

Use supplies designed for this laminator.

On the PC, click **Retry**, or click **Cancel** to cancel the card.

206: L2 supply problem

The L2 supply is not moving properly. To try another card:

1. Open the laminator and remove the L2 cartridge.
2. Reposition, repair, or replace the supply and advance the repaired area one full turn.
3. Replace the cartridge and close the laminator.

On the PC, click **Retry**, or click **Cancel** to cancel the card.

207: L2 supply out or missing

The laminator does not have usable supplies.

1. Open the laminator.
2. Replace the supply.
3. Close the laminator.

On the PC, click **OK**, or click **Cancel** to cancel the card.

208: L2 supply type problem

The laminator cannot use the supply installed.

Use supplies designed for this laminator.

On the PC, click **Retry**, or click **Cancel** to cancel the card.

209: L2 supply not supported

The laminator cannot use the supply installed.

Use supplies designed for this laminator.

On the PC, click **Retry**, or click **Cancel** to cancel the card.

210: L2 supply not identified

The laminator cannot use the supply installed.

Use supplies designed for this laminator.

On the PC, click **Retry**, or click **Cancel** to cancel the card.

211: L1 heater problem

The laminator has encountered a critical error. The card will be canceled.

1. Press the printer POWER button to power off the system.
2. Request service. The system must remain powered off.

On the PC, click **OK** to clear the message.

212: L2 heater problem

The laminator has encountered a critical error. The card will be canceled.

1. Press the printer POWER button to power off the system.
2. Request service. The system must remain powered off.

On the PC, click **OK** to clear the message.

213: L1 heater sensor problem

The laminator has encountered a critical error. The card will be canceled.

1. Press the printer POWER button to power off the system.
2. Request service. The system must remain powered off.

On the PC, click **OK** to clear the message.

214: L2 heater sensor problem

The laminator has encountered a critical error. The card will be canceled.

1. Press the printer POWER button to power off the system.
2. Request service. The system must remain powered off.

On the PC, click **OK** to clear the message.

215: L1 heater roller problem

The laminator has encountered a critical error. The card will be canceled.

1. Press the printer **POWER** button to power off the system.
2. Request service. The system must remain powered off.

On the PC, click **OK** to clear the message.

216: L2 heater roller problem

The laminator has encountered a critical error. The card will be canceled.

1. Press the printer **POWER** button to power off the system.
2. Request service. The system must remain powered off.

On the PC, click **OK** to clear the message.

217: Debow problem

The laminator has encountered an error in the debow area.

1. Remove the card.
2. Press the printer **POWER** button to power off the system.
3. Press the printer **POWER** button again to power on the system.
4. If the problem occurs again, request service.

On the PC, click **Retry**, or click **Cancel** to cancel the card.

218: Impresser problem

The laminator has encountered a critical error. The card will be canceled.

1. Press the printer **POWER** button to power off the system.
2. Request service. The system must remain powered off.

On the PC, click **OK** to clear the message.

219: Impresser sensor problem

The laminator has encountered a critical error. The card will be canceled.

1. Press the printer **POWER** button to power off the system.
2. Request service. The system must remain powered off.

On the PC, click **OK** to clear the message.

220: Impresser heater problem

The laminator has encountered a critical error. The card will be canceled.

1. Press the printer POWER button to power off the system.
2. Request service. The system must remain powered off.

On the PC, click **OK** to clear the message.

221: Bar code scanner problem

The bar code scanner cannot read the bar code on the overlay. This can indicate a scanner problem, an unreadable bar code, or an incorrect L1 cartridge.

Try the card again.

If the problem occurs again, request service.

On the PC, click **OK** to clear the message.

222: Firmware version mismatch

The printer and attached component firmware versions are not compatible. The system cannot process cards until the firmware has been updated.

Update both the printer and component to the latest firmware versions.

223: Laminator system mismatch

The printer and laminator are not compatible.

The laminator is not supported by your printer model. Contact your service provider for the correct laminator model.

Driver-Only Messages

The following messages are issued by the Card Printer Driver and display on the PC that sent the card print job. These messages do not display on the printer LCD panel.

500: The printer is not available

The computer cannot communicate with the printer. To complete the current card:

1. Make sure that the printer is powered on and in the **Ready** state.
2. Make sure the printer is connected to the computer using a USB or network cable, but not both.

When the printer is ready, click **OK**.

Click **Cancel** if you want to cancel the card

501: The printer connection was lost

The computer lost communications with the printer during printing. The card will be canceled.

1. Make sure the printer is powered on.
2. Make sure the printer connection to the computer is secure.

Click **OK** to clear the message.

502: The card data is missing or is not usable

The printer driver has detected invalid or missing data. The card will be canceled.

Make sure the data being sent is formatted properly and matches the options and settings in the printer.

Click **OK** to clear the message.

504: The card data is missing or is not usable

The printer driver has detected invalid or missing data. The card will be canceled.

Make sure the data being sent is formatted properly and matches the options and settings in the printer.

Click **OK** to clear the message.

505: USB communication issue

An important driver component is not running. The card will be canceled.

1. Restart the computer. The component should start automatically.
2. If this message is displayed after restarting, notify your printer support contact.

Click **OK** to clear the message.

506: A card is currently processing

The printer is busy processing an interactive job. The card will be canceled.

Wait until the current card is complete and then try again.

Click **OK** to clear the message.

507: The printer is unlocked

The printer must be locked to print.

To complete the current card make sure that all access doors are closed securely and locked.

Click **OK** to clear the message, or click **Cancel** to cancel the card.

508: The printer is shutting down

The printer is shutting down or resetting. The card will be canceled.

When printer is powered back on, try again.

Click **OK** to clear the message.

509: The printer is offline or suspended

The printer must be online to print.

To complete the current card press the printer's **USER** button until the printer returns to the **Ready** state.

Click **OK** to clear the message, or click **Cancel** to cancel the card.

510: The printer is unlocked

The printer must be locked to resume printing.

Make sure that all access doors are closed securely and locked.

Click **OK** to clear the message, or click **Cancel** to cancel the card.

Driver SDK Messages

The following messages are issued when you use an application with the Card Printer Driver Software Development Kit (SDK) to define your card printing. These messages display at the computer that sent the job and are available to the application through the driver API.

In addition, printer errors display on the printer LCD panel, at the computer that sent the job, and are available to the application through the driver API (refer to [“Messages and Conditions”](#) on page 84).



The messages returned to the SDK are determined by the printer model and the options installed on the printer. The following messages may not apply to all printers.

511: Cannot lock or unlock the printer. Locks are not installed.

Severity: Critical

512: Cannot lock or unlock the printer. The password is incorrect or invalid.

Severity: Critical

513: Cannot lock or unlock the printer. The printer is busy.

Severity: Notice

514: Cannot lock or unlock the printer. The cover is open.

Severity: Notice

515: Failed to lock or unlock the printer. The locks did not function.

Severity: Critical

516: Timeout expired before bar code could be read.

Severity: Notice

517: Wrong printer job ID.

Severity: Critical



Appendix A: CR805 Card Printer with Inline Lamination

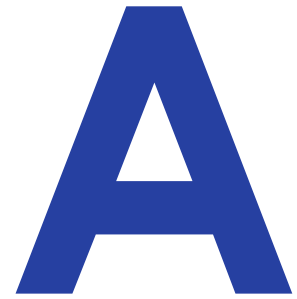

This appendix provides information about the optional CLM laminator that you can add to your CR805 retransfer card printer at the time of purchase or later, as a field upgrade.

About the Laminator System

A laminator system consists of a CR805 card printer and a CLM laminator. The system can print cards and apply an overlay material on the front and back of the card for increased durability and security. Using an overlay material with holographic or other transparent images also improves the security of the card. These materials are tamper evident, making it difficult to reproduce or modify a card.



Your laminator may look different from the one shown in the illustrations, based on the options installed. The information described in this appendix applies to all CLM laminators.

Single-Hopper System

Multi-Hopper System

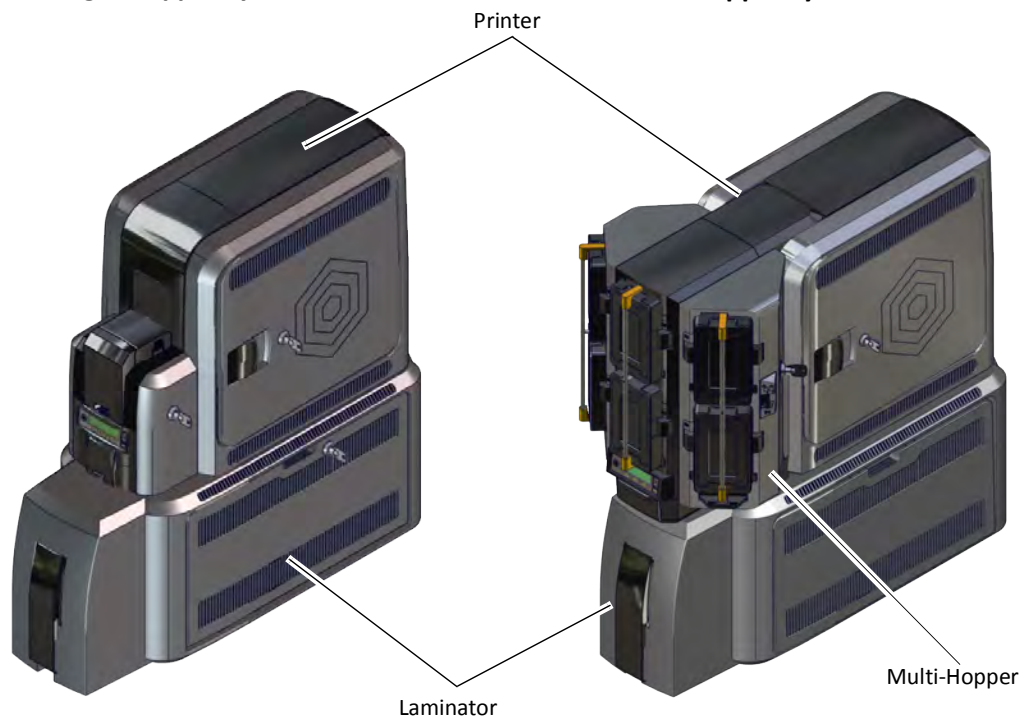

Outside the Laminator

Use the following information to become familiar with the laminator.



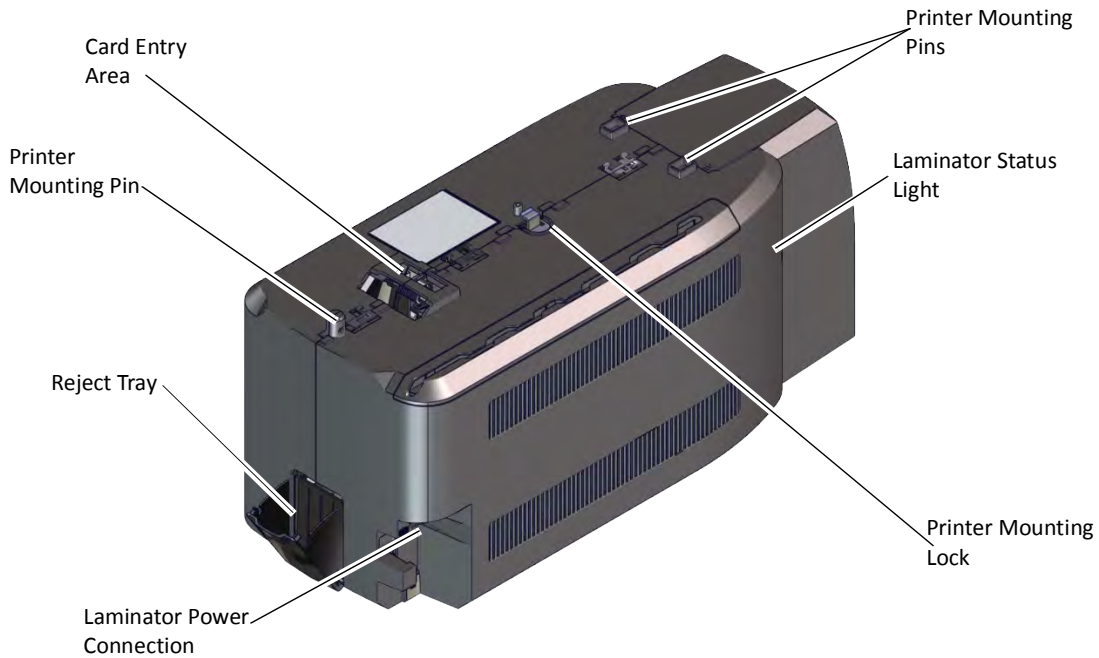

Laminator Back and Left Side



- | | |
|-----------------------------------|--|
| Printer Mounting Pins | The pins align the printer with the laminator. |
| Printer Mounting Lock | The lock secures the printer to the laminator. |
| Laminator Status Light | The light shows the status of the laminator. Refer to “Laminator Status Light” on page A-3 . |
| Card Entry Area | The card entry area receives the card from the printer and places it into position for laminating. |
| Reject Tray | Unfinished cards or cards not processed properly are placed in the reject tray. Refer to “Inside the Laminator” on page A-4 to see the location of the reject tray release button. |
| Laminator Power Connection | The power connection provides a plug-in connector for the laminator power supply. |

Laminator Status Light

The status light shows the status of the laminator:

Ready	Solid green	
Busy	Blinking green	
Idle/Sleeping	Solid blue	
Heating	Blinking blue	
Error	Blinking red	

Laminator Front and Right Side

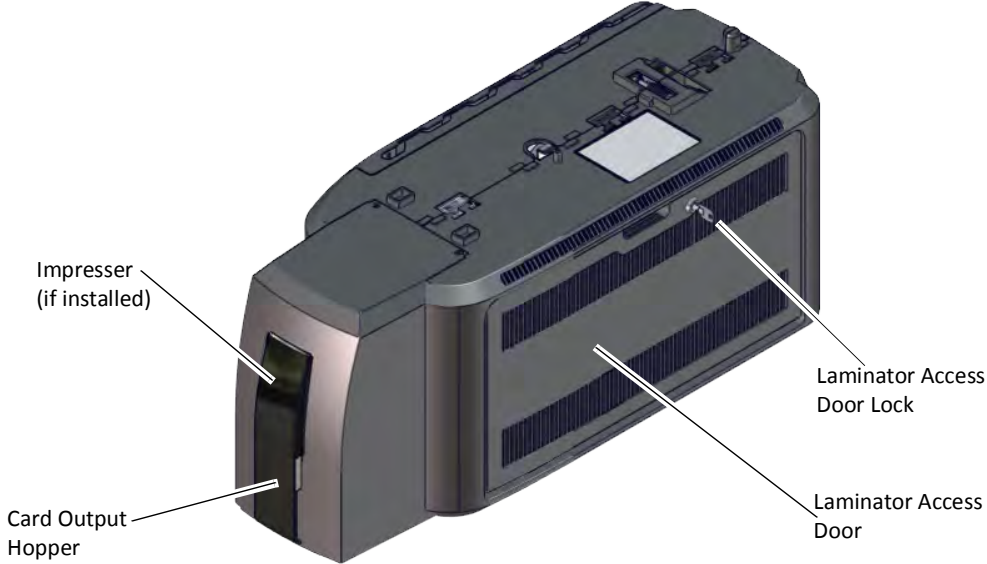

- Card Output Hopper** The card output hopper holds up to 100 completed cards.
- Laminator Access Door** The access door provides access to the laminator supplies.
- Laminator Access Door Lock** The lock provides secure access to the laminator.
- Impresser** The optional impresser is located inside the laminator just before the card exit slot.

Inside the Laminator

The CLM laminator has one standard laminator, in the L1 position, with an optional second laminator in the L2 position. The laminators apply a patch overlay material to the card. The patch overlay is a die-cut polyester shape designed to fit standard ISO ID-1 size card stock. Both laminators can apply the overlay. Refer to [“Laminator Overlay Materials”](#) on page A-6.

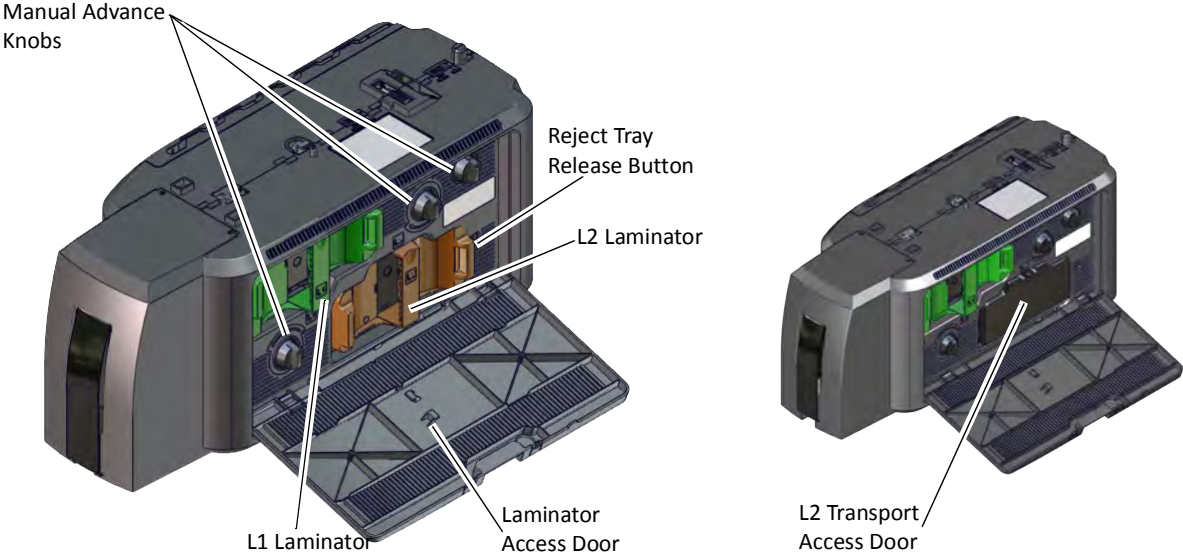

Manual Advance Knobs The manual advance knobs move the card through the laminator to remove it from the system. Use the knobs to clear a card jam.

L1 Laminator (green cartridge) The L1 laminator cartridge holds the overlay material and applies it to the card.

L2 Laminator (orange cartridge) The L2 laminator cartridge holds overlay material and applies it to the card. The L2 laminator is optional.

Reject Tray Release Button The release button opens the reject tray at the back of the laminator and allows you to remove incomplete cards.

Laminator Access Door The access door provides access to the L1 and L2 laminators to load supplies or to clear a card jam.

L2 Transport Access Door The L2 transport access door replaces the L2 laminator cartridge if the optional second laminator is not installed. Open the door to access the laminator card transport.

 If your system includes the optional second laminator (L2), make sure that the laminator cartridge is always installed even if the cartridge is not loaded with overlay material. If the cartridge is not in place, cards are not supported as they travel through the system and can fall into the bottom of the laminator.

Laminator Configuration Label

The laminator configuration label is located inside the laminator beneath the L2 cartridge.

The configuration label shows the following information:

- Laminator name
- Serial number
- Configuration
- Part number
- Date and country of assembly.

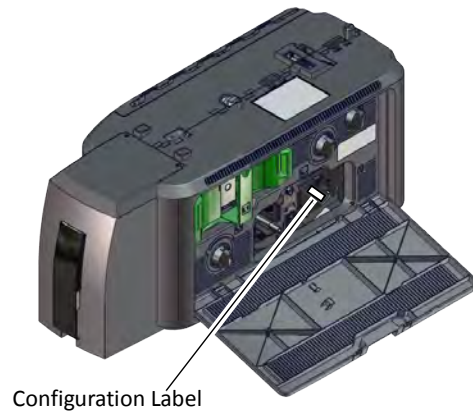

Additional labels may be attached to indicate options installed by the dealer or sales group after the laminator was manufactured.

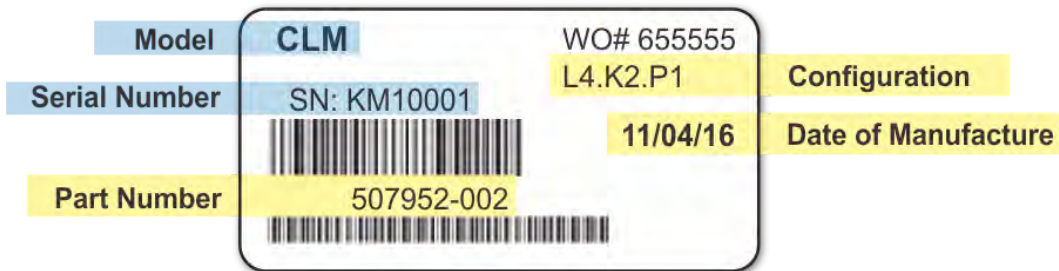

Option	Configuration Code
Laminator	L3=Rubber roller in L1 Laminator L4=Rubber roller in L1 and L2 Laminators
Locks	K1=Mechanical Locks K2=Electronic/Mechanical Locks blank=No Lock
Other Options	P1=Impresser

Laminator Setup

The laminating system applies a patch overlay to the card to provide additional protection against wear.

Laminator Overlay Materials

The L1 and L2 laminators each can apply a patch overlay, which is a die-cut polyester shape.



Patch Overlay

Patch overlays have a registration mark that is used by the laminator to align the patch with the beginning of the card. The registration mark is a rectangular hole between the patches.

Patches can cover the entire card, can have an opening for a smart card chip, or can cover the card below the magnetic stripe. If both L1 and L2 laminators are installed, each laminator can apply different overlay material. For example, you might apply a patch that covers the complete card on the front, and a patch sized for a magnetic stripe on the back.



Complete Card

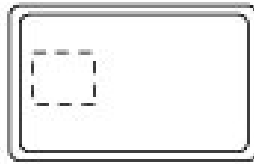

Smart Card

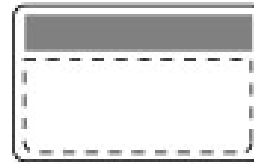

Magnetic Stripe

The patch overlay can be clear or it can have a transparent holographic image on it. The holographic materials are called holographic patch and can be ordered with a custom image.



Clear Patch



Random Holographic Patch

In addition, the holographic patch can be designed with a registered image that is located in the same position on each card. Refer to the printer's *Installation and Administrator's Guide* for information about ordering overlay material.



Registered Holographic Patch



If you use a custom holographic overlay, make sure that you know the location of important card features, such as photos and logos. Do not place holographic images where they interfere with the appearance of photos or machine-readable features.

Load Laminator Overlay Material

Load the overlay material in one laminator cartridge at a time.

i The L1 (green) and L2 (orange) cartridges fit only in their assigned locations inside the laminator. They are not interchangeable.

- 1. Unlock and open the laminator access door.
- 2. Remove the L1 (green) laminator cartridge from the printer. Place the cartridge on a smooth level surface for loading.



- 3. Push the release latch (a) and open the gate on the laminator cartridge (b).

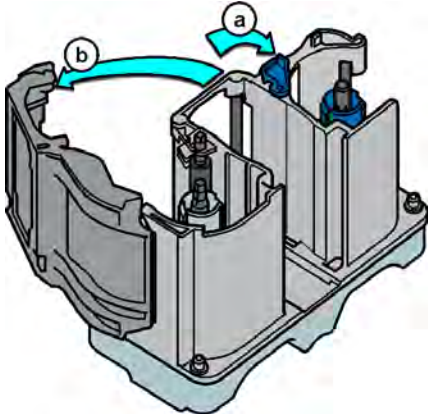

- 4. Remove both used spools from the cartridge (if present).

5. Load the new roll of laminator overlay material.

- a. Put the blue supply spool on the blue supply spindle of the cartridge (c). The overlay supply roll can go on only one way and only fits on the correct spindle.
- b. Put the empty silver take-up spool on the silver take-up spindle (d).
- c. Turn the take-up spool clockwise to remove slack from the material (e). The overlay material loads in an S-shape.

Make sure that the overlay material is between the guides on both the take-up and supply sides of the cartridge.

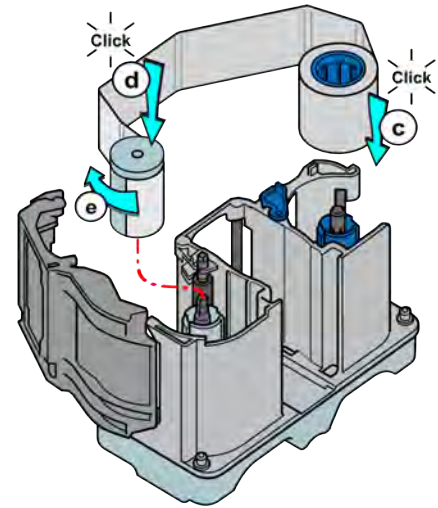

6. Close the laminator cartridge gate (f). Push it in until the latch clicks in place (g). Make sure that the overlay material is not pinched by the cartridge gate.

- 7. Replace the loaded laminator cartridge in the printer.
- 8. Remove the L2 (orange) cartridge, if installed, from the laminator.
- 9. Repeat steps 3 through 7 to load the overlay onto the L2 cartridge.

10. Close and lock the laminator access door.

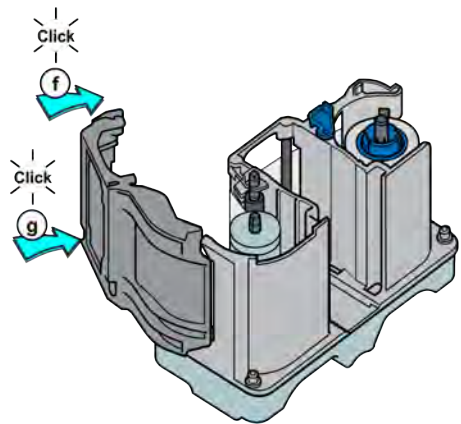

Card Design

Set up your card design using your card production software or another application, such as Microsoft Word. You can specify your lamination preferences using the Card Printer Driver. Your card production software also may provide lamination settings.

The Card Printer Driver allows you to specify both printer and lamination preferences. Refer to the *XPS Card Printer Driver User's Guide* for complete information about setting up printing preferences and lamination options.

- If the printer has one laminator, you can apply the overlay material to one or both sides of the card.
- If the printer has two laminators using different overlay materials, the quickest way to process a card is to apply the overlay in L1 to the front of the card and the overlay in L2 to the back of the card.

You can fine-tune the settings that control the application of the overlay using Printer Manager. Refer to the printer's *Installation and Administrator's Guide* for information about using Printer Manager.

Verify Setup

After you set up the printer, print several test cards to determine how well the laminator applies material to the card. You can print test cards from the Card Printer Driver (refer to the *XPS Card Printer Driver User's Guide*) or from the printer LCD panel (refer to [“Print a Test Card”](#) on [page 28](#)). You may need to print multiple test cards to make sure that the overlay is positioned correctly. The card stock, the card design, and the printer's environment all can affect the appearance of cards.

When evaluating a card, make sure that:

- The overlays are being applied properly:
 - Each overlay is applied completely to the card.
 - The material adheres well to the edges of the card.
 - The overlay does not come off when the card is bent or twisted.
- The card is debowed correctly.
- The impression is positioned correctly and has the proper depth.

If you need to make adjustments to the laminator or overlay settings, refer to the “Printer Manager” section of the printer's *Installation and Administrator's Guide*.

Empty the Laminator Reject Tray

Unfinished cards, or cards that were not processed properly, are placed in the laminator reject tray.



The printer reject tray is not used when the laminator is present. Rejected cards are always placed in the laminator reject tray.

1. Unlock and open the laminator access door.
2. Press the reject tray release button to open the laminator reject tray. (Refer to [“Inside the Laminator”](#) on page A-4.)
3. Remove the rejected cards from the reject tray.
4. Close the reject tray.
5. Close and lock the laminator access door.



Clear a Laminator Card Jam

1. Unlock and open the laminator access door.
2. Remove the L1 and L2 (if installed) laminator cartridges.
3. Turn the manual advance knobs inside of the laminator until the card is accessible.
4. Remove the card.
5. Replace the laminator cartridges.
6. Close and lock the laminator access door.

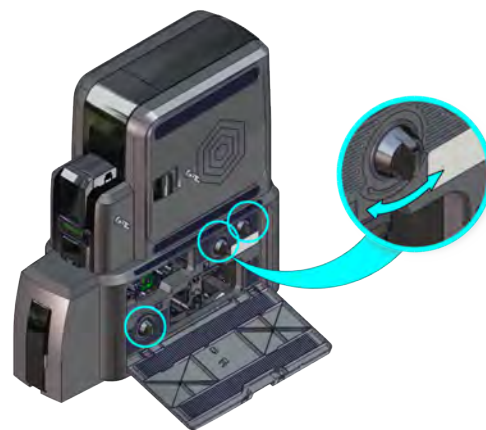

Clean the Laminator

Clean the laminator when at least one laminator cartridge is loaded with holographic overlay material and any of the following are true:

- Particles appear on the laminated cards.
- Particles are visible inside the laminator.

For examples of problems that require laminator cleaning, refer to [“Laminator Troubleshooting”](#) on [page 77](#).



This procedure uses a double-sided, adhesive cleaning card that removes holographic overlay particles from the laminator. When you clean the system using an adhesive cleaning card or isopropanol cleaning card, the card also moves into the laminator and cleans the laminator rollers, the card entry area, and the impresser exit rollers. This is sufficient if you are not using holographic overlay. Refer to [“Clean the Printer”](#) on [page 47](#).

1. Unlock and open the laminator access door.
2. Remove the L1 and L2 laminator cartridges.

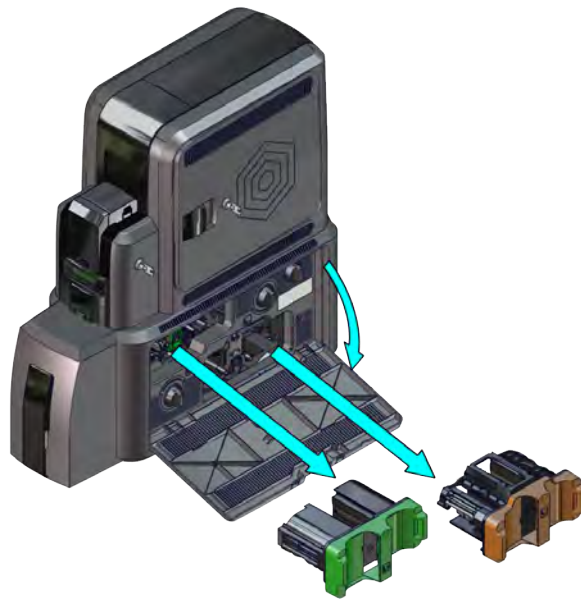

3. Remove printed cards from the output hopper, if necessary.

4. Remove the protective paper from both sides of the double-sided, adhesive cleaning card and insert the card under the rollers of the card exit slot of the laminator. When it is in the correct location and pushed in far enough, the card stays in place.

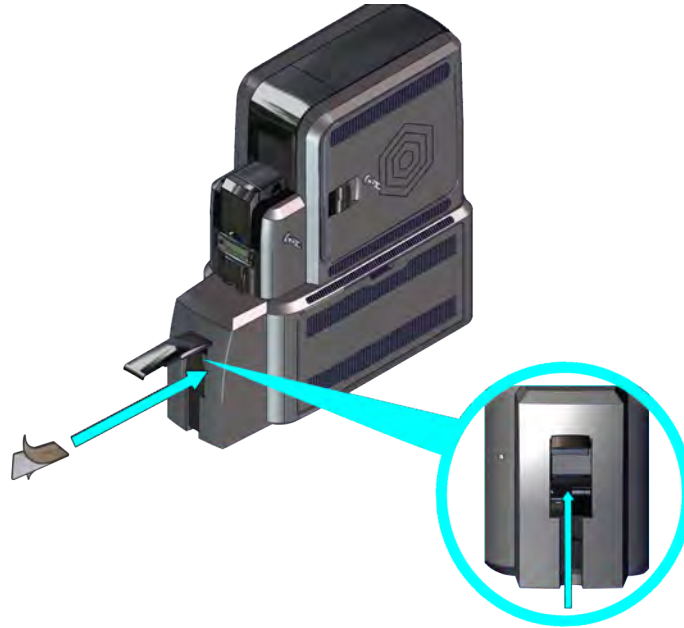

5. Use the LCD menu system to start the cleaning cycle.
 - a. Begin when the printer displays **Ready** and the USER button shows steady green. Press the USER button.
Suspended displays on line 1 of the LCD panel.
 - b. Press ENTER to enter the menu system.
 - c. **Maintenance** displays on line 2 of the LCD panel. Press ENTER to enter the **Maintenance** menu.
 - d. **Cleaning Card** displays on line 2 of the LCD panel. Press ENTER to enter the **Cleaning Card** menu.
 - e. **Printer** displays on line 2 of the LCD panel. Press the down arrow.

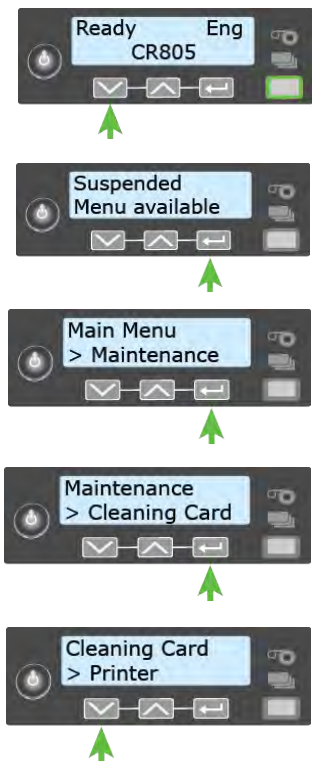

f. **Laminator** displays on line 2. Press ENTER.

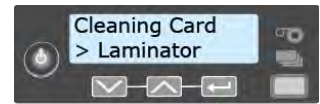

g. **Start** displays on line 2 of the LCD panel. Press ENTER to start the cleaning process.



h. **Insert cleaning card** displays on the LCD panel. Press the USER button to start the cleaning cycle.

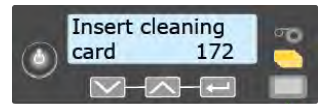

The laminator pulls the cleaning card from the card exit slot into the laminator and moves it back and forth through the L1 and L2 cartridge areas, the card entry area, and the exit rollers several times. If the system has locks, the used card is ejected into the laminator reject tray. If the system does not have locks, the used card is ejected into the laminator output hopper.

6. Inspect the laminator cartridges for particles. If particles are present:
 - a. Retrieve the laminator cleaning card and use it to remove the particles of overlay material from the cartridges.
 - b. If particles still remain on the cartridge and inside of the laminator, use a vacuum cleaner with a small plastic hose attachment to carefully remove the particles. Also clean any remaining particles from the output hopper.

HINTS & TIPS

- If the cleaning card is not pulled into the laminator, the card is not in the correct position. The cleaning card must be located under the rollers of the card exit slot inside the output hopper.
- At the end of the laminator cleaning cycle, the card can stick to the rollers in the output hopper. Pull on the card to remove it.
- Discard the cleaning card after one use.
- Avoid contact with the heated roller, which contains sensitive electronic components.
- If cleaning the laminator does not solve the problem, contact your service provider for assistance.

