

# CD820 Printer Repackaging

**i** The printer activation code is required before proceeding. If this code is unavailable, contact Datacard Customer Support at 1-800-328-3996 with the printer serial number to obtain the code.

1. Disable the printer.
  - A. Press and hold the user button on the printer until **Suspended Menu Available** displays on the LCD panel, and then press the enter key to enter the Main menu.

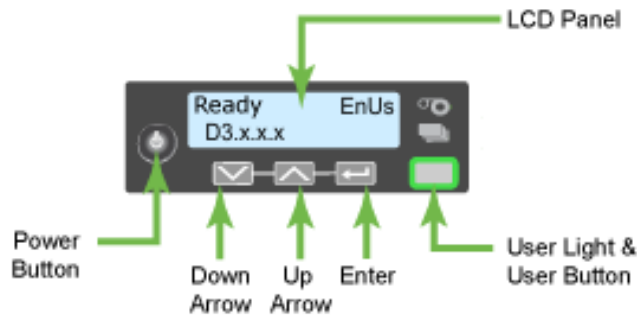

- B. Press the down arrow key until **Activate** displays on line 2 of the LCD panel.
    - C. Press the enter key to enter the **Activate** menu.

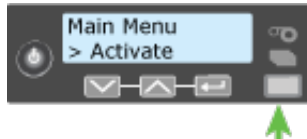

- D. Press the down key until **Disable** displays on line 2 of the LCD panel.
      - E. Press the enter key to enter the **Disable** menu.

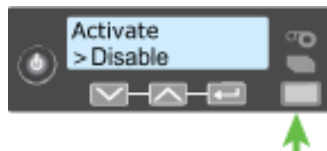

- F. Enter the code used to activate the system.



- G. Press the up and down arrow keys to cycle through the alpha and numeric characters. Press enter to select each character that matches the 8-digit numeric code. When **Request Success** displays on line 2 of the LCD panel, the system is inactivated.
          - H. Press and hold the power button to shut down the power to the system.

2. Secure internal components (multi-hopper only).
  - A. Unlock printer and place the original shipping restraint into the body of the printer.
  - B. Secure the shipping restraint behind the multi-hopper.

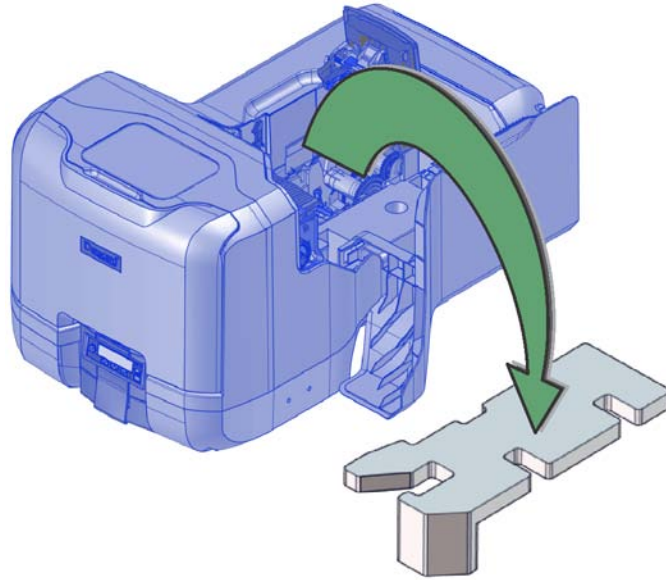

3. Close and lock the printer.

 Do not repackage the key with the unit.

4. Box the printer for shipping.

Single-hopper printer only:

- A. Secure the printer into the foam inserts above and below and at both ends of the unit.
- B. Place the printer with foam inserts into the box and place the cardboard insert above.
- C. Wrap shipping tape around the box and cover to secure the container for shipping.

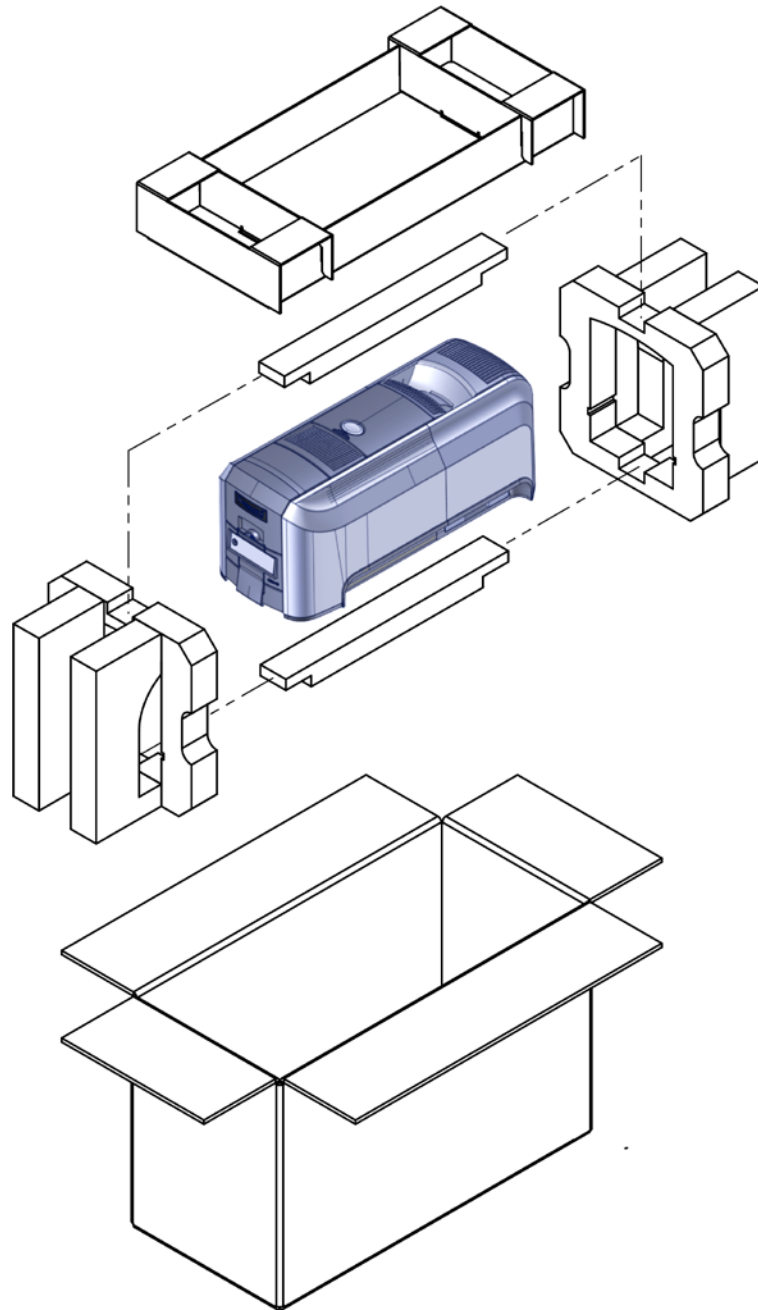

Multi-hopper printer only:

- A. Secure the printer into the foam inserts at both ends of the unit.
- B. Center the unit with inserts on the unfolded box.

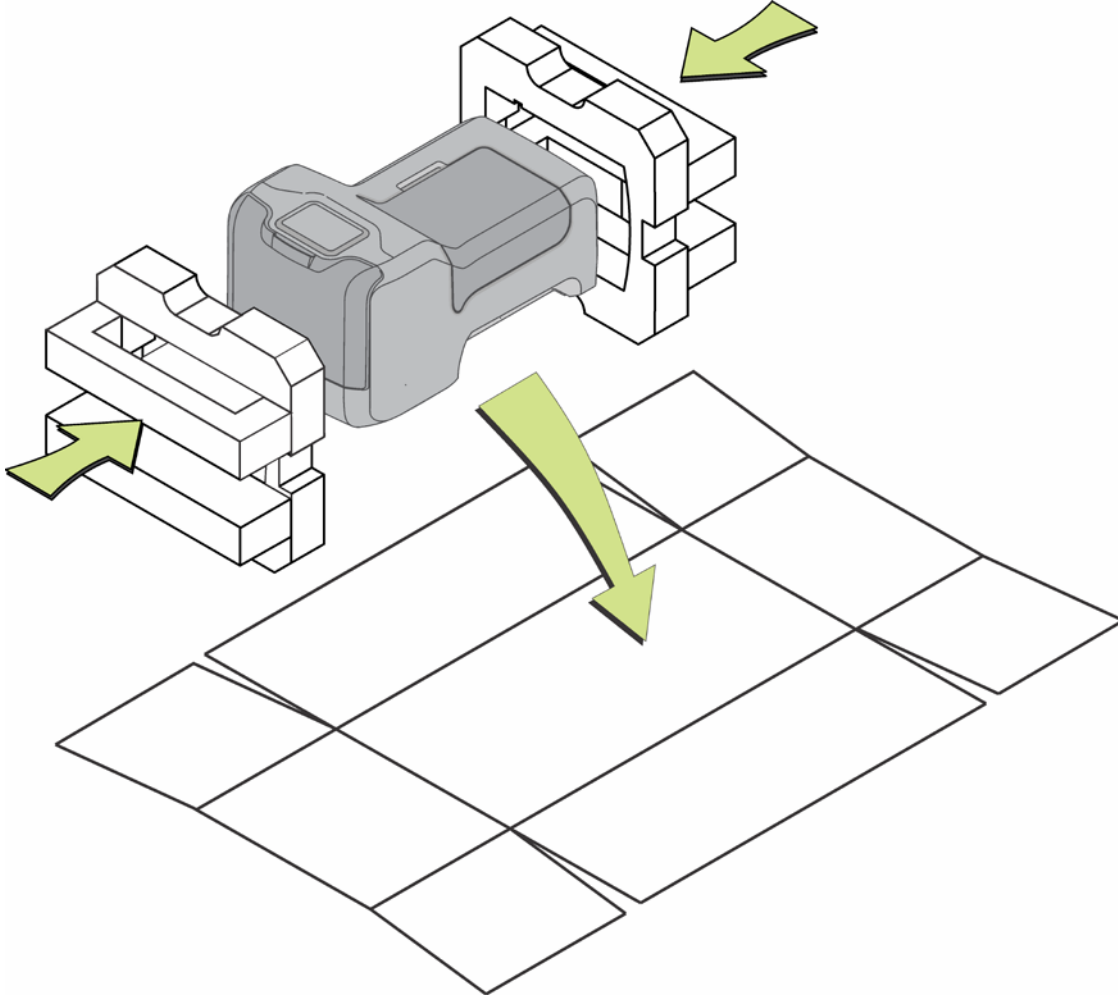

**i** Use the unit's original box with the bar-coded configuration label on the outside. If the original packaging is unavailable, order a replacement by contacting Datacard Customer Support at 1-800-328-3996 or email [North\\_America\\_Cust\\_Serv@datacard.com](mailto:North_America_Cust_Serv@datacard.com).

- C. Fold the box around the unit with inserts.
- D. Secure the folding of the box using the 4 "T" tabs.
- E. Place the cover on top of the box.

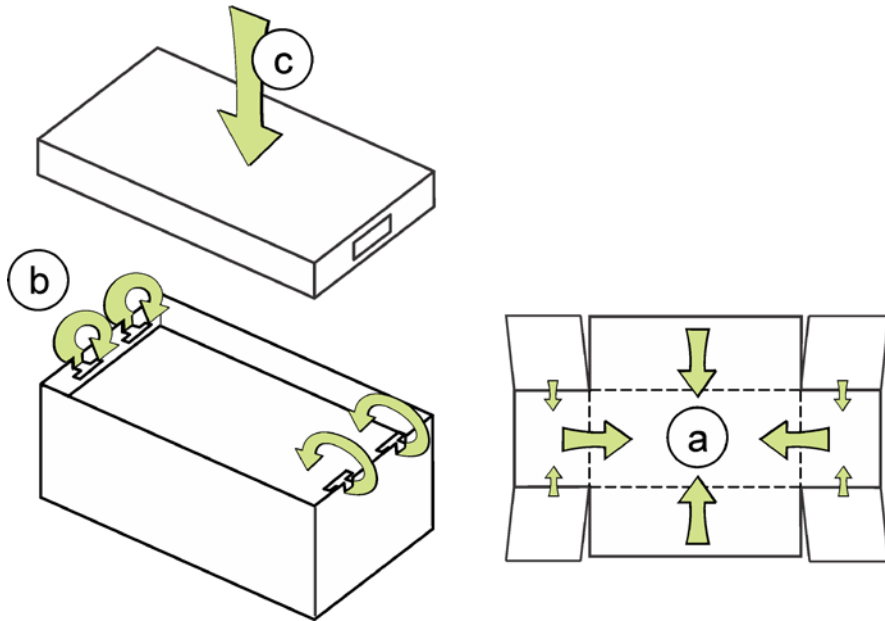

- F. Insert and close the two plastic handles to secure the cover to the box.

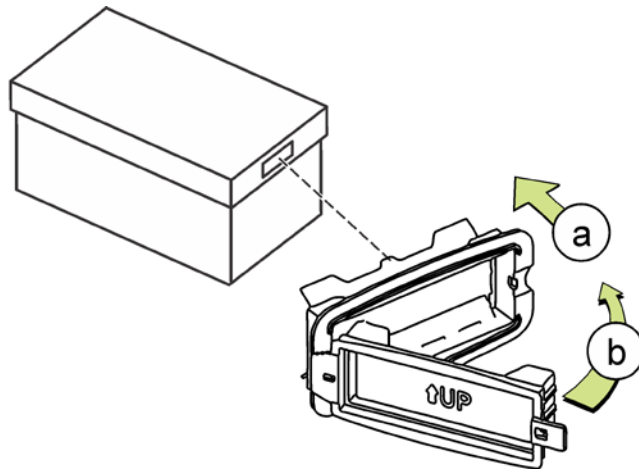

- G. Wrap shipping tape around the box and cover to secure the container for shipping.