

# Datacard<sup>®</sup>

CE870™ Instant Issuance System

## Quick Install Guide

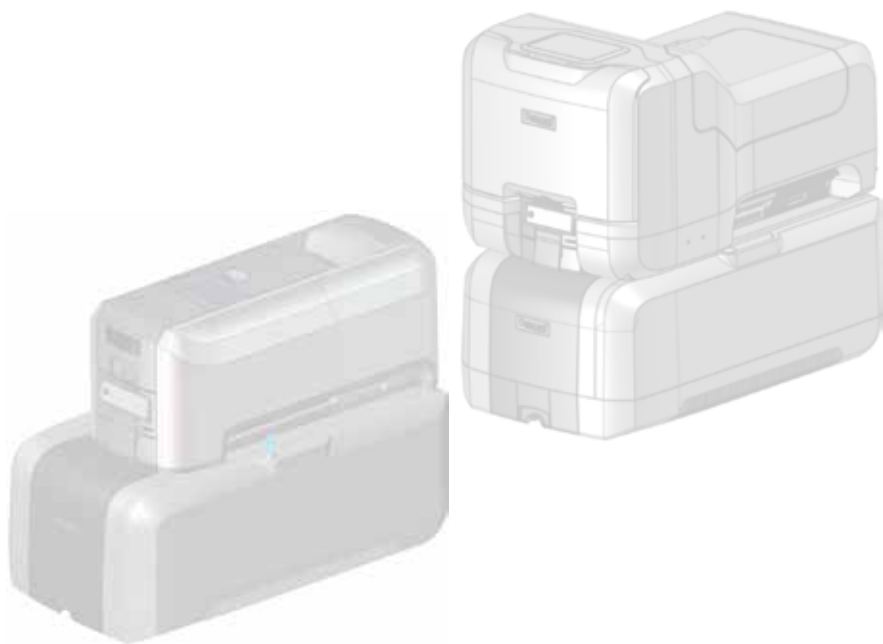

Refer to your printer's *Installation and Administrator's Guide*, found on the *Owner's Library* CD, for detailed installation instructions.

## 1. Select a Location for the Printer

- Install the printer in a location that is clean and well ventilated, free of vibration or shock.
- For venting and clearance, choose an area that has the following measurements:
  - **Single-Hopper System:** 27 inches (686 mm) wide, 31 inches (788 mm) deep, and at least 27.4 inches (696 mm) high.
  - **Multi-Hopper System:** 28 inches (711 mm) wide, 41 inches (1041 mm) deep, and at least 30 inches (762 mm) high.

Refer to the printer's *Installation and Administrator's Guide* for complete site requirements.

- Do not install the printer in direct sunlight.
- Install the system in a secure location.
- Install the system in a location that has access to two AC outlets and a network port.

## 2. Unpack the System

Remove the printer and the embosser from their shipping cartons.

### Single-Hopper Printer

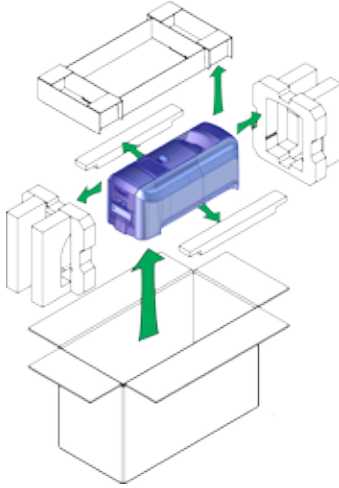

### Multi-Hopper Printer

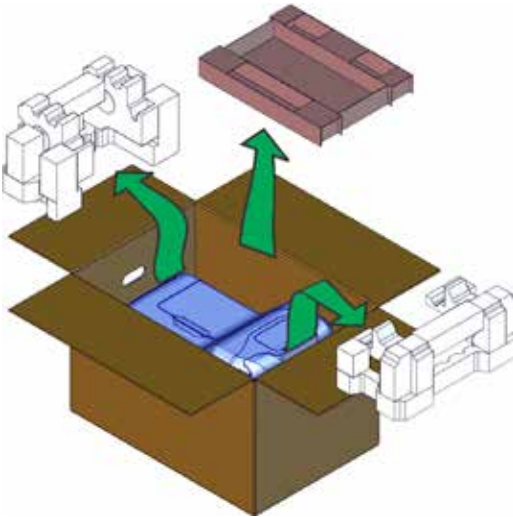

## Embosser

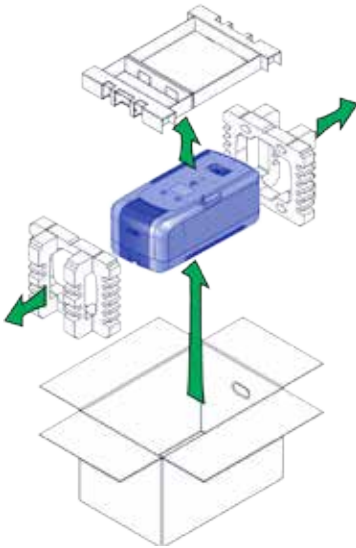

## 3. Remove Shipping Items

- a. (Multi-hopper printer only): Unlock the printer and open the printer supplies access door and the multi-hopper cover.
- b. Remove the packing material inserted behind the hopper and inside the cover.

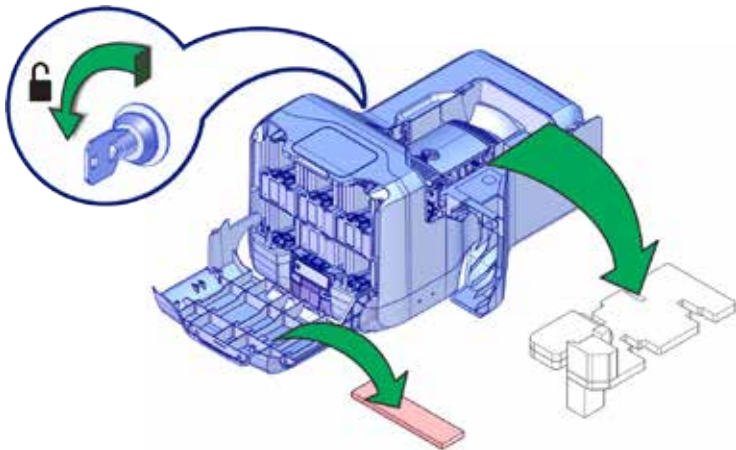

# CE870 Instant Issuance System Quick Install Guide

- c. Unlock the embosser and remove the indent ribbon and topping foil cartridges.

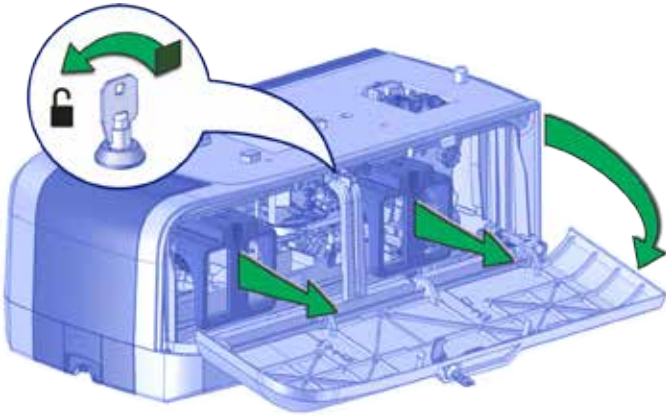

- d. Remove the foam "T" and block inserts used to secure the embosser topping and transport mechanisms during shipping.

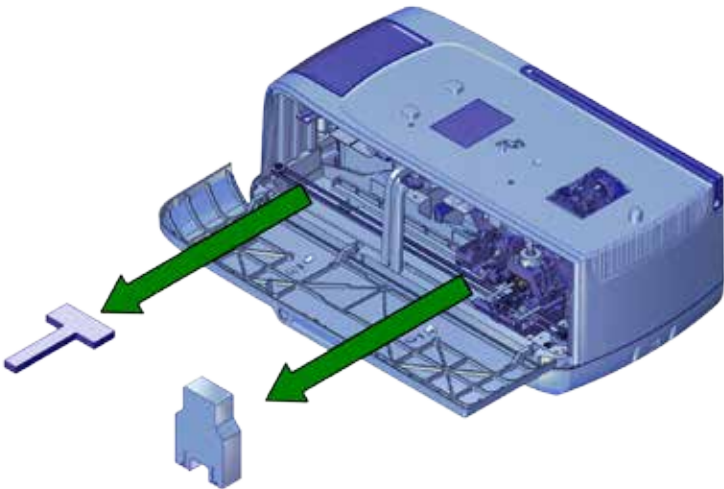

## 4. Secure the System

- a. Secure the embosser to the work surface (if required). Refer to the printer's *Installation and Administrator's Guide* for detailed installation instructions and measurements.

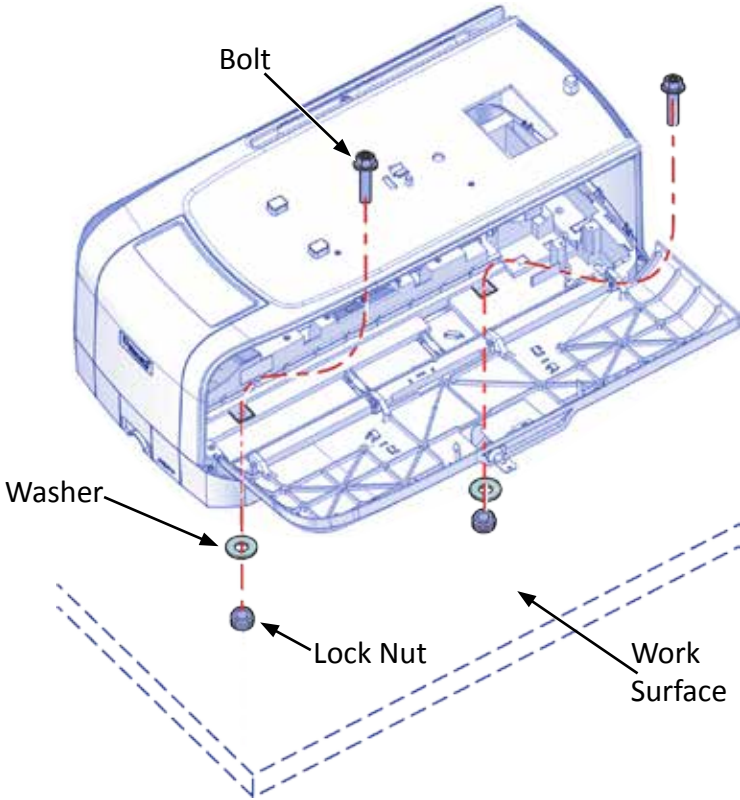

## 5. Assemble the Printer and Embosser

- a. Locate the interconnect cable in the cable routing area of the embosser, and make sure that it remains accessible.
- b. Slide the printer locking lever inside the embosser to the left to move the mounting lock to the unlocked position.

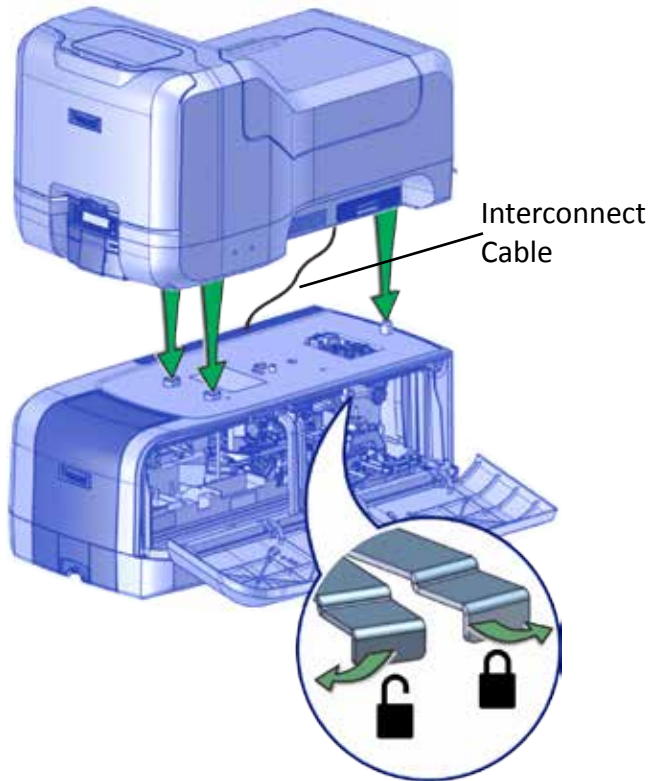

- c. Lift the printer over the embosser and align the pins on the embosser with the holes on the underside of the printer.

## CE870 Instant Issuance System Quick Install Guide

---

- d. Press down carefully, but firmly, on the printer to position it.
- e. Push the printer locking lever to the right to lock the printer to the embosser. Make sure that the printer is locked securely to the embosser.
- f. Connect the interconnect cable from the embosser to the lower data port on the printer.

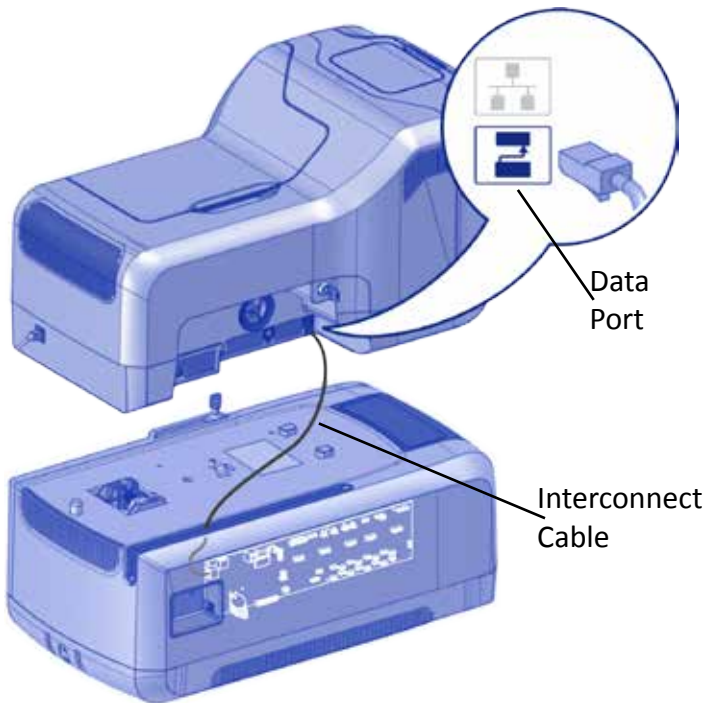



## 6. Connect the Power Cords

- Connect the printer power cord into the printer and into the power supply.
- Connect the power supply cord into the power outlet.

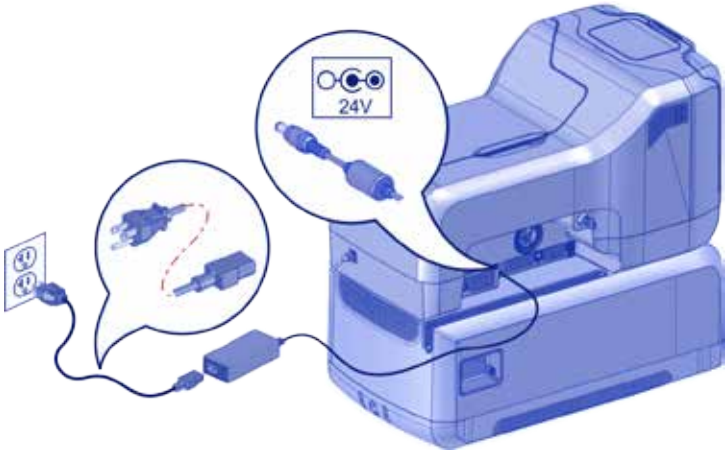

- Connect the embosser power cord into the embosser and power supply.
- Connect the power supply cord into the power outlet.

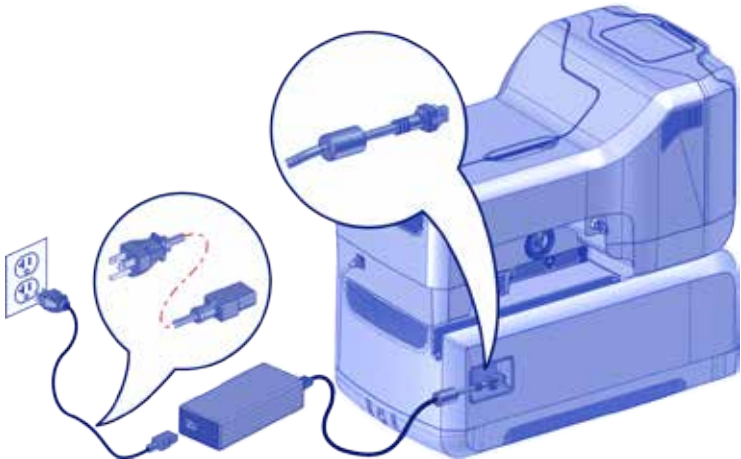

## 7. Load Supplies

Supplies are ordered separately.

- a. Load the indent ribbon onto the cartridge.

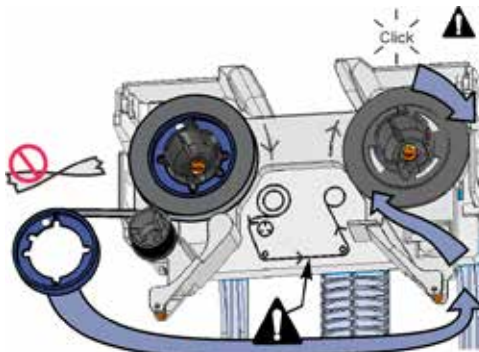
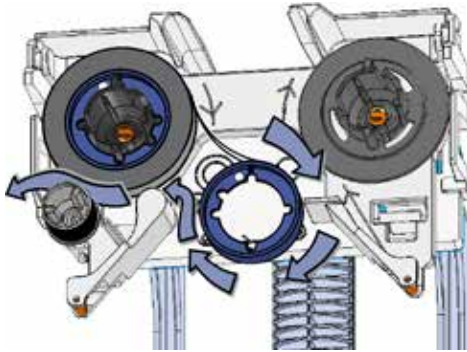
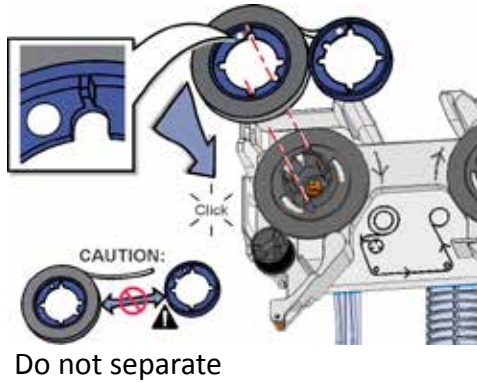

# CE870 Instant Issuance System Quick Install Guide

b. Load the topping foil onto the cartridge.

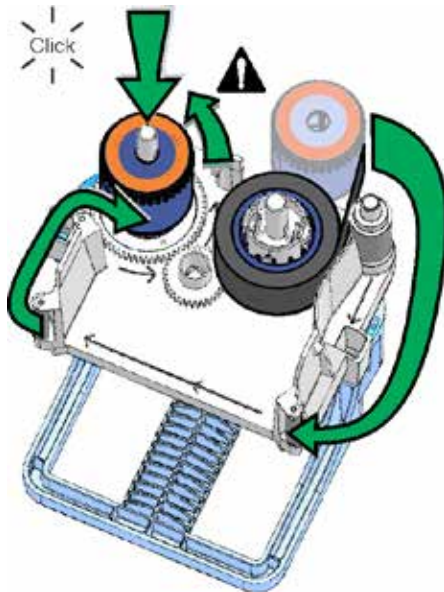
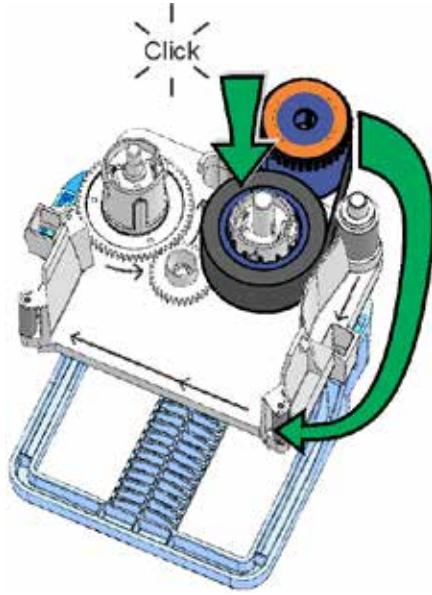

c. Replace the cartridges in the embosser.

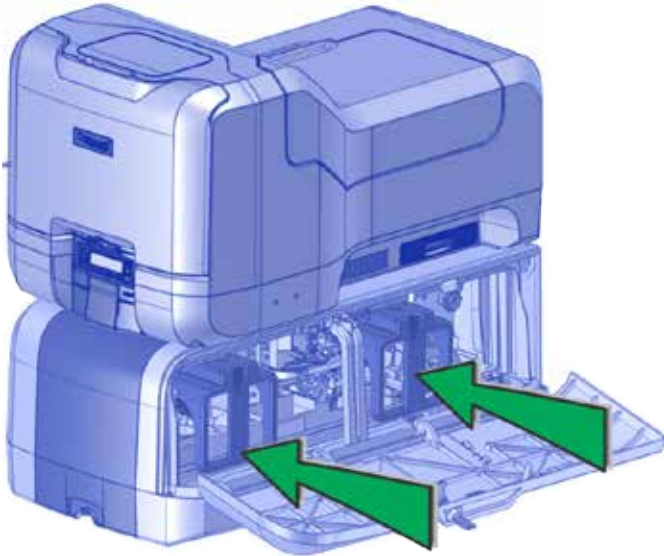

d. Remove the print ribbon cartridge.

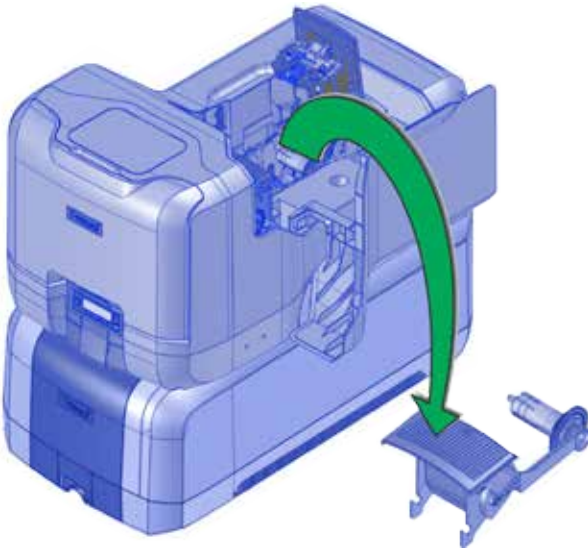

- e. Load the cleaning sleeve onto the cartridge.

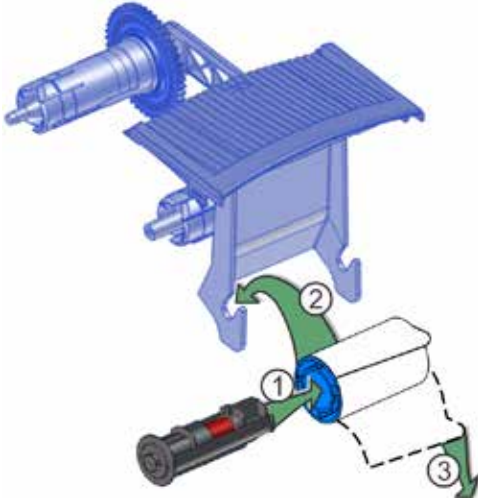

- f. If your printer is equipped with the optional printhead, load the print ribbon onto the cartridge.

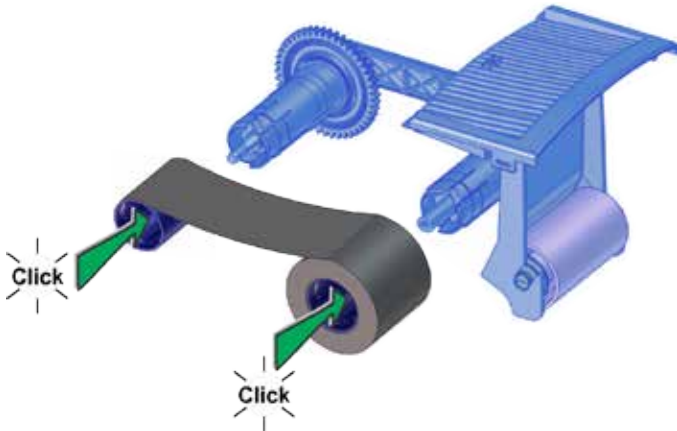

- g. Install the print ribbon cartridge in the printer.

- h. Load the cards in the input hopper. Refer to the diagram inside the hoppers for the correct orientation.

## Single Hopper



## Multi-Hopper

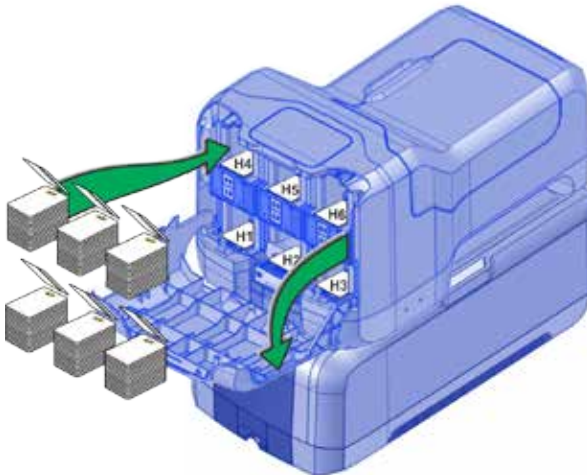

- i. Close and lock all printer and embosser doors.

## 8. Power On the System

- a. Press the power button on the front panel to power on the system.
- b. Wait until the system has powered up and **Print queue is deactivated** displays on the LCD panel.

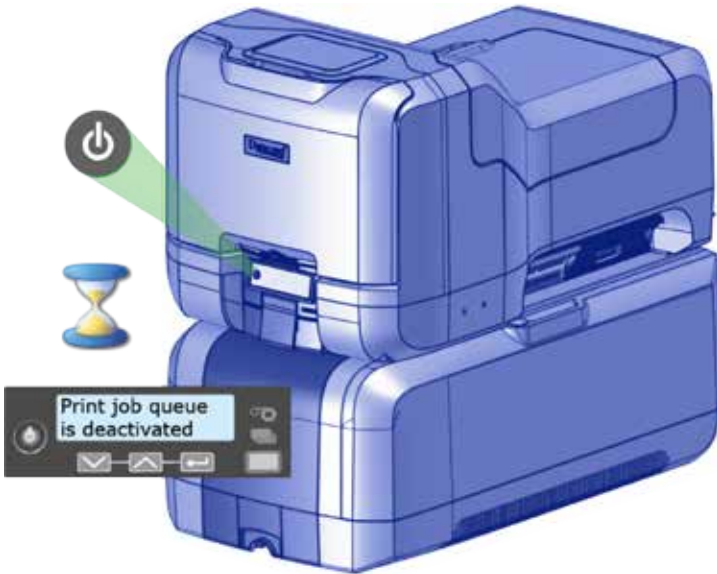

## 9. Activate the System Through the Front Panel

- a. Before you start the activation process, call Datacard Technical Support at 1-800-328-3996 to obtain the activation code.
- b. Have the printer and embosser serial numbers ready when you call. The printer serial number is located on the printer swingarm label and on the configuration label located on the outside of the shipping box. The embosser serial number is on the configuration label located inside of the embosser on the lower enclosure.

Printer

Configuration  
Label

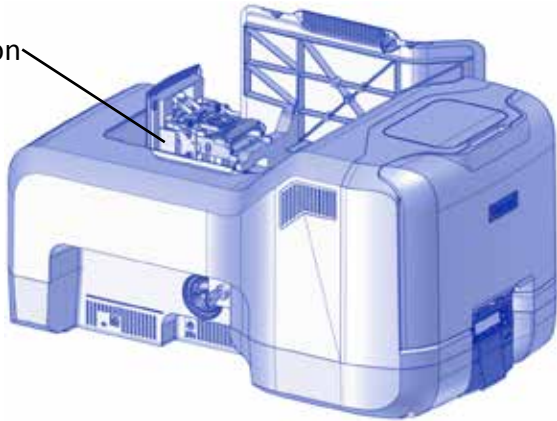

Embosser  
Configuration  
Label

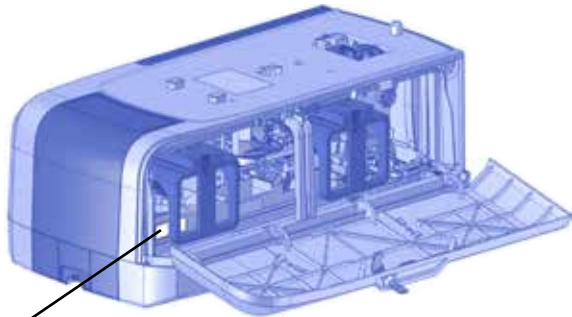



c. Enter the activation code.

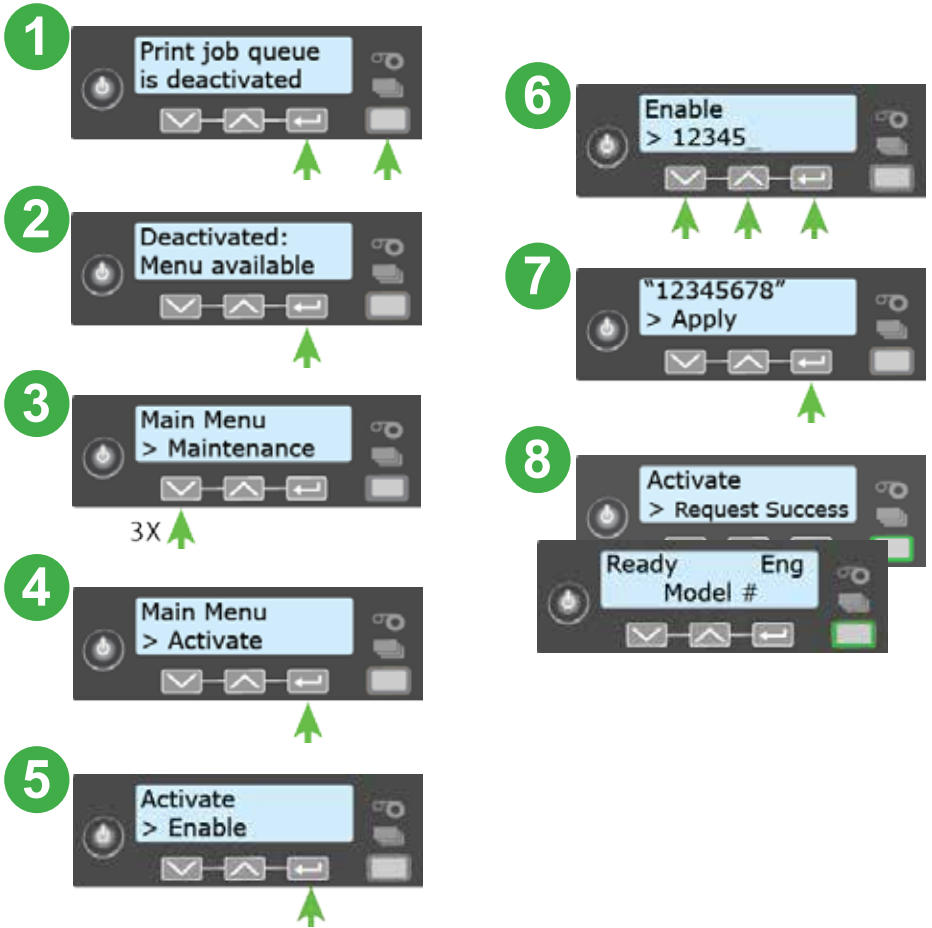

## 10. Connect the Network Data Cable

The cable is ordered separately.

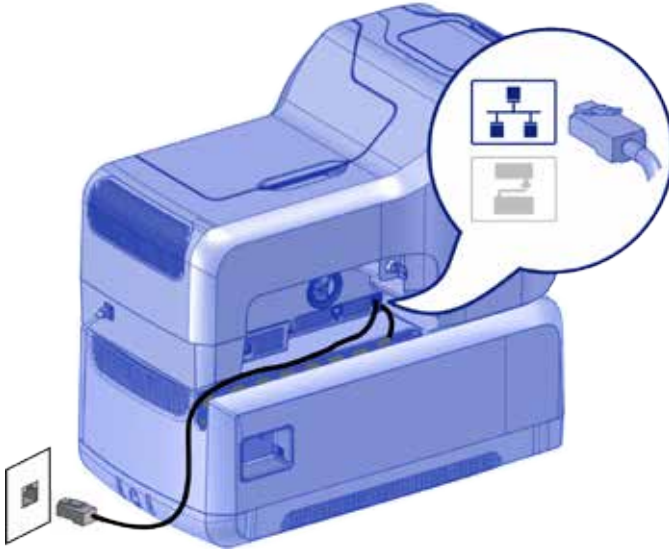

## 11. Set a Static IP Address

Datacard® CardWizard® issuance software requires the printer to have the same IP address at all times.

- a. Obtain the following information from your system administrator:

IP address \_\_\_\_\_

Subnet mask \_\_\_\_\_

Gateway address \_\_\_\_\_

# CE870 Instant Issuance System Quick Install Guide

- b. Use the front panel menu system to enter the IP address information.

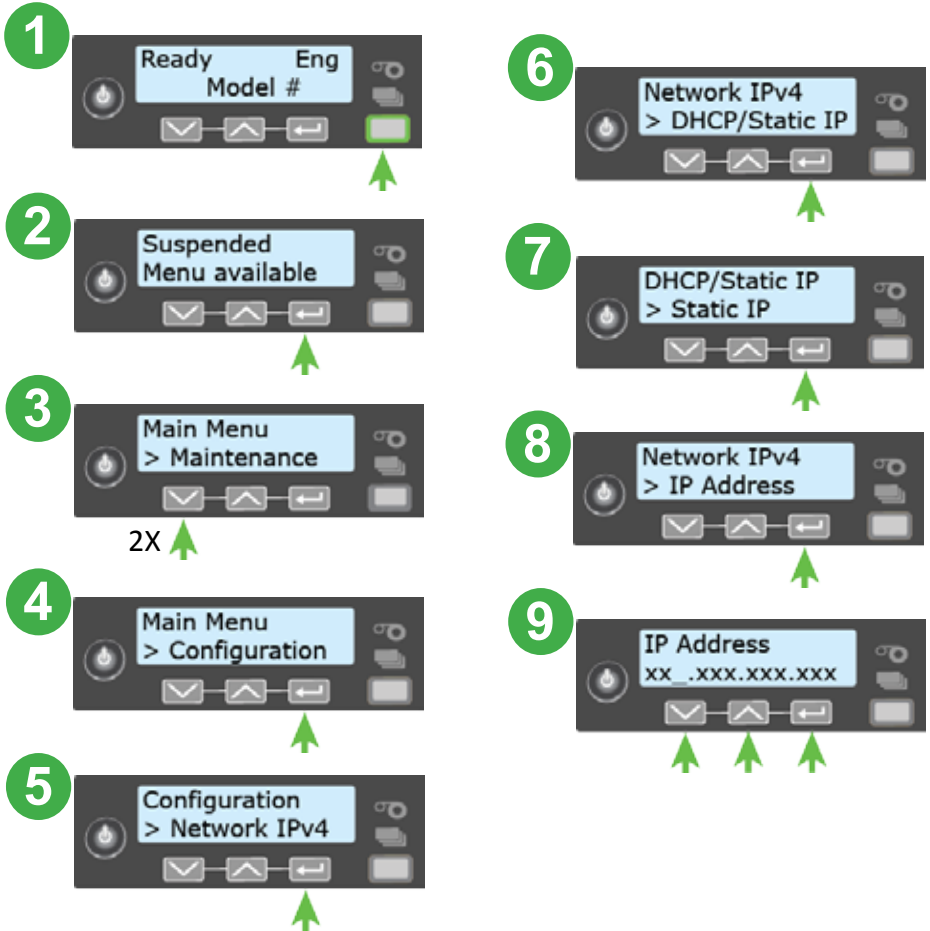

- c. Follow the same process to set the subnet mask and gateway address.

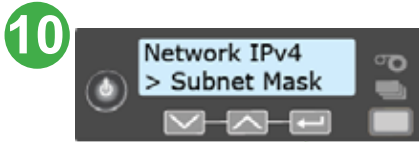

## 12. Print a Test Card (Optional)

- a. Using an internet browser, enter `https://xxx.xxx.xxx.xxx`, where `xxx.xxx.xxx.xxx` is the printer IP address.
- b. Log on to Printer Manager as WebAdmin.



- c. Select Troubleshooting > Test Card.

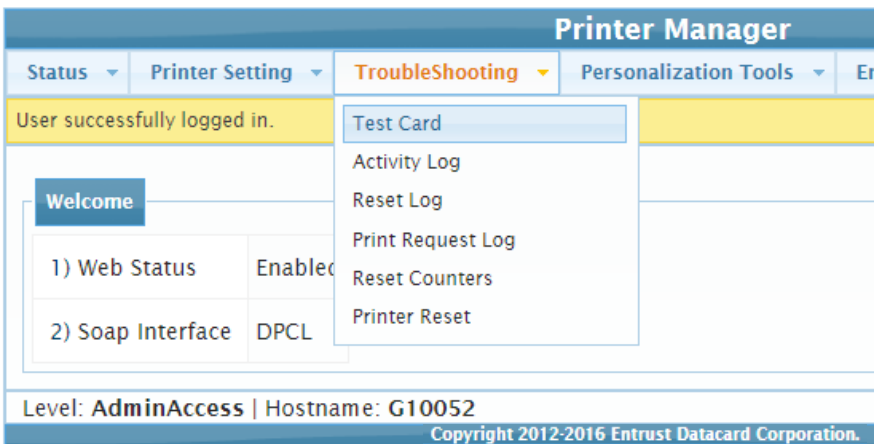

- d. Select the **Emboss** test card option and the test card to run. Each test card tests the position and quality of embossed and indented characters. Refer to the printer's *Installation and Administrator's Guide* for a description of the test cards.

**Note:** If your printer does not have a printhead installed, do not select the **Color** check box.

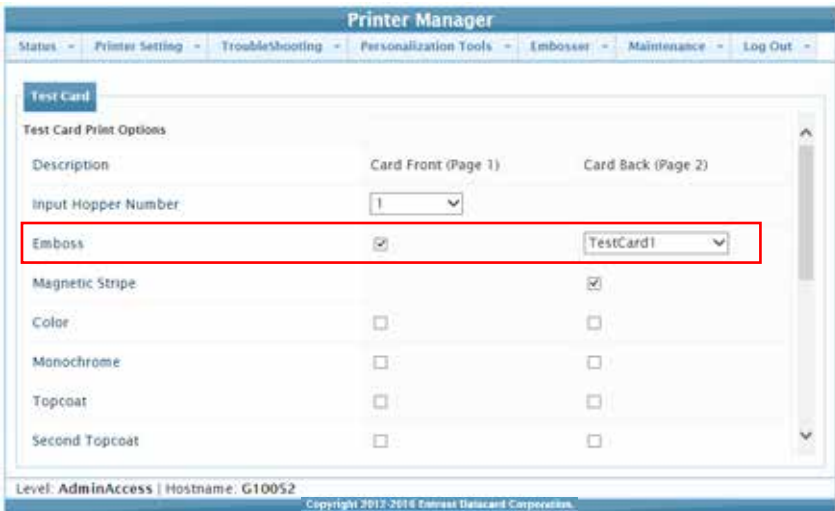

The screenshot shows the 'Printer Manager' web interface. The 'Test Card' section is active, displaying 'Test Card Print Options'. The 'Input Hopper Number' is set to '1'. The 'Emboss' option is checked and highlighted with a red box. The 'Card Back (Page 2)' dropdown menu is set to 'TestCard1'. Other options like 'Magnetic Stripe', 'Color', 'Monochrome', 'Topcoat', and 'Second Topcoat' are also visible.

| Description         | Card Front (Page 1)                 | Card Back (Page 2)                  |
|---------------------|-------------------------------------|-------------------------------------|
| Input Hopper Number | 1                                   |                                     |
| Emboss              | <input checked="" type="checkbox"/> | TestCard1                           |
| Magnetic Stripe     |                                     | <input checked="" type="checkbox"/> |
| Color               | <input type="checkbox"/>            | <input type="checkbox"/>            |
| Monochrome          | <input type="checkbox"/>            | <input type="checkbox"/>            |
| Topcoat             | <input type="checkbox"/>            | <input type="checkbox"/>            |
| Second Topcoat      | <input type="checkbox"/>            | <input type="checkbox"/>            |

Level: AdminAccess | Hostname: G10052  
Copyright 2012-2018 Entrust Datacard Corporation.

- e. Click **Run** to print the test card.

## 13. Next Steps

- Define the printer to CardWizard software. Refer to the *CardWizard and Card Printer Setup Guide* for information.
- Contact your system administrator to set up the rest of the system.
- Set up security, including network authorization to the printer.
- Refer to the printer's *Installation and Administrator's Guide* for detailed installation instructions.

Please complete a brief survey about your product installation experience at:

<https://www.datacard.com/datacard-product-installation-report>

**Warning:** This product contains chemicals, including lead, known to the State of California to cause cancer, and birth defects or other reproductive harm. *Wash hands after handling.*

For more information on this warning, refer to:  
[www.datacard.com/califpropwarning](http://www.datacard.com/califpropwarning).

# Datacard®

1187 Park Place  
Shakopee, Minnesota 55379  
952.933.1223 • 952.933.7971 Fax  
[www.datacard.com/id](http://www.datacard.com/id)

Datacard is a registered trademark and service mark of Entrust Datacard Corporation, and Entrust is a registered trademark and service mark, in the United States and other countries. All other trademarks are the property of their respective owners.

© 2012–2017. The design and information contained in these materials is protected by US and international copyright law.